

Iron, Steel and Aluminium in the UK:

Material Flows and their Economic Dimensions

Executive Summary Report

April 2004

Kristina Dahlström^a, Paul Ekins^a,
Juanchun He^b, Jennifer Davis^b, and Roland Clift^b



Aluminium ingot made from recycled cans © Alfed



Port Talbot blast furnace © Corus

Biffaward Programme on Sustainable Resource Use

Objectives

This report forms part of the Biffaward Programme on Sustainable Resource Use. The aim of this programme is to provide accessible, well-researched information about the flows of different resources through the UK economy based either singly or on a combination of regions, material streams or industry sectors.

Background

Information about material resource flows through the UK economy is of fundamental importance to the cost-effective management of resource flows, especially at the stage when the resources become 'waste'.

In order to maximise the Programme's full potential, data will be generated and classified in ways that are both consistent with each other, and with the methodologies of the other generators of resource flow/ waste management data.

In addition to the projects having their own means of dissemination to their own constituencies, their data and information will be gathered together in a common format to facilitate policy making at corporate, regional and national levels.

Project Team and Contributors

The project was funded by Biffaward under the Landfill Tax Credit Scheme, with contributions from Corus Research Technology & Development and the European Aluminium Association's (EAA) Aluminium For Future Generations Programme. The University of Surrey Environmental Body (USEB) was the body approved by Entrust to distribute the funds.

In addition to financial support from the above-mentioned organisations, the project could not have been undertaken without the invaluable and extensive guidance, expertise, and data kindly provided by the members of the project's Steering Committee, for which the authors are extremely grateful.

Steering Committee

Mark Askew, Alfred
Joan Chesney, Alcan
David Harris, Alfred
Colin Honess, Corus
Phil Hunt, ISSB
Christian Leroy, EAA
Michael Sansom, Steel Construction Institute

Several other people also provided assistance, information, comments and feedback. Additional thanks therefore go specifically to Jonathan Aylen from UMIST; Pauline Dowling and Rick Hindley from Alcan; Cherry Hamson from Alupro; John May from Corus Steel Packaging Recycling; and James Ley from the Steel Construction Institute. Roland Geyer, Adisa Azapagic and Tim Jackson at the Centre for Environmental Strategy (CES), Surrey, also assisted in earlier stages of the project.

Any remaining errors in the report are the sole responsibility of the authors. Opinions expressed are also those of the authors and not necessarily those of the organisations and individuals mentioned here.

A full project report, comprehensively detailing the methodology, findings, and data sources used, has been produced. To obtain a copy of the *Iron, Steel and Aluminium in the UK: Material Flows and their Economic Dimensions: Final Project Report*, please contact Centre Administrator, Centre for Environmental Strategy at the University of Surrey (01483 686670), m.a.ellis@surrey.ac.uk.

Table of Contents

Biffaward Programme on Sustainable Resource Use	ii
Project Team and Contributors	iii
1. Introduction	1
2. Material Flow Analysis Methodology	4
3. Material Flow Analysis Findings	7
4. Value Chain Analysis Methodology	15
5. Value Chain Analysis Findings	19
6. Conclusions	26
7. References	32
Appendix: Mass Balance Reports	33

1. Introduction

Economic activity is associated with resource flows related to the extraction, production, consumption or use, and disposal of materials and products. Information on the quantities of these flows, relating to specific materials, economic sectors, or geographic areas, is vital for sustainable resource management, particularly at the end-of-life stage where resources become wastes. In light of rising waste disposal costs and other increasingly stringent environmental legislation, the management of resource flows is gaining importance both at the level of individual companies and industries, and as a policy issue.

The *Mass Balance* suite of Biffaward projects, coordinated by the Sustainable Economy Programme of Forum for the Future, has generated data on resource flows through the UK economy, in a common framework to maximise the usefulness of the data (Linstead and Ekins, 2001). The projects rely on the mass balance principle, grounded in thermodynamic laws, that the total mass of inputs must equal the total mass of outputs, in some form. This principle of balance helps uncover hidden flows in the economy, such as in the form of emissions to air or stocks of materials, for example stocks of a material contained in a landfill.

This report is the joint report of two separate projects funded under the Biffaward Mass Balance programme: the *Material Flows of Iron/Steel and Aluminium in the UK*, undertaken at the Centre for Environmental Strategy (CES) at the University of Surrey; and the *Economic Dimensions of Material Flows of Iron/Steel and Aluminium in the UK*, undertaken at the Policy Studies Institute (PSI). In practice, the two projects functioned in many respects as one project with two distinct parts, and there was a high level of mutually beneficial collaboration between the project partners. Throughout the report, the former project is referred to as the material flow analysis (MFA), and the latter project as the value chain analysis (VCA).

Project Objectives

The purpose of the MFA was to provide a reliable set of time series data on the flows and stocks of iron/steel and aluminium as they pass through the UK economy. The MFA collected and synthesised yearly data, going back for iron/steel to the 1960s and for aluminium to the 1950s, on the material flows associated with the production, use, recovery and reuse of iron/steel and aluminium in the UK. This included data on primary and secondary raw materials; finished materials such as iron and steel products and semi-finished aluminium products; metal content in final goods containing steel and aluminium; and imports and exports of these materials.

In addition to these material flows, the MFA also used a time series approach to model the stocks in use (i.e. iron/steel and aluminium contained in goods) and hence to estimate the end-of-life (EOL) scrap arisings. Iron/steel and aluminium exist in a range of goods with different lengths of service lives, such as packaging materials, vehicles, or buildings – some of which can remain in use for several decades. The modelling approach therefore has to allow for the length and distribution of these different service lives.

To enhance the policy relevance of the MFA, a parallel VCA related the material flows to economic variables, as this consideration of economic dimensions sheds further light on such concepts as resource productivity and sustainable resource management. The purpose of the VCA was to provide a methodology for investigating the economic values associated with the current material flows and stocks of steel and aluminium in the UK; to map the value chain corresponding to the material flows; and to examine how these values relate to resource productivity and recovery.

Policy Context

Sustainable resource use, which concerns both ensuring adequate supplies of renewable and non-renewable resources and managing the environmental impacts associated with their processing and use, is firmly established in UK environmental policy. National policy is increasingly driven by European initiatives and shaped through the implementation of specific EU Directives and the interpretation of more general strategies. The current EU Sixth Environmental Action Programme (European Commission, 2001) identifies sustainable use of resources and management of waste as one of four priority areas for action. In addition, sustainable resource management in general and resource productivity improvements in particular are fundamental to delivering sustainable development as defined by the UK government (DETR, 1999), as high and stable levels of economic growth need to be achieved with social progress, prudent use of natural resources and effective protection of the environment.

The issue of waste management is particularly relevant for the UK, which has traditionally relied on cheap landfill as a means of waste disposal. England and Wales produce around 400 million tonnes (Mt) of waste every year, most of which is landfilled. Over 100 Mt of this waste comes from households, industry and commerce, with the balance made up of construction and demolition, agricultural and mining wastes. An estimated 83% of household waste and 54% of industrial and commercial waste is sent to landfill, making recovery rates very low compared with many other parts of Europe. Landfilling is becoming increasingly problematic: not only does it represent a loss of potentially valuable resources, but it is also polluting and gives rise to emissions of methane, a greenhouse gas; it is unpopular with those who have to live near landfill sites; certain parts of the country, such as the South East, are running out of space in their available landfill sites; and the EU Landfill Directive requires the UK to achieve significant reductions in the landfilling of biodegradable wastes over the next ten years. The Waste Strategy for England and Wales (DETR, 2000) is the UK Government's response to these challenges and is aimed at household and industrial and commercial waste. It sets ambitious targets for the reduction, recovery and recycling of these wastes (see Box 1.1).

The Government is also committed to environmental tax reform: using fiscal measures to increase incentives to reduce environmental damage by taxing the use of environmental resources rather than labour. The landfill tax, introduced in 1996, applies a charge per tonne of waste disposed of in landfill. There are two rates of tax: one for inert waste, such as concrete or ash, currently set at £2/tonne; and one for all other active wastes, which is currently set at £14/tonne. The UK rate for active waste is currently escalating at £1/tonne per year, until 2004/05, when it will rise by £3/tonne per year until it reaches a medium-term rate of £35/tonne. However, some other European countries already have considerably higher landfill taxes, such as the Netherlands, which has a landfill tax of £45/tonne, and Denmark, with a rate of £34/tonne (Strategy Unit, 2002).

Box 1.1 Targets for Industrial and Commercial Waste

- reduce the amount of industrial and commercial waste going to landfill to 85% of that landfilled in 1998 by 2005

Targets for Municipal and Household Waste

Recovery (obtaining value through recycling, composting, or other forms of material recovery):

- recover value from 40% of municipal waste by 2005; from 45% by 2010; and from 67% by 2015

Recycling and Composting of Household Waste:

- recycle or compost at least 25% of household waste by 2005; 30% by 2010; and 33% by 2015

The UK Steel and Aluminium Industries

Steel and aluminium are two of the commonest structural metals in the UK, and are produced and exist in society in great quantities. The concept of sustainable development presents particular challenges for primary industries such as these, because environmental sustainability requires the conservation and prudent use of non-renewable resources and the management of environmentally damaging impacts associated with the extraction and processing of these resources. However, because of the value of steel and aluminium, well-established techniques and infrastructure have been developed to recycle these metals, with significant savings in energy and material inputs and a reduction in environmental impacts as a result. In the UK, key environmental concerns for the steel industry are the emissions of air pollutants and the management of solid wastes, and for the aluminium industry the key concern is the generation of greenhouse gases.

The two industries face similar pressures and trends, related to the evolving environmental legislation of the EU, and to the changing structure of the UK economy as well as increasing globalisation of trade. The metals industry has experienced a high rate of consolidation in the past decade, which looks set to continue. In the steel industry, the consolidations occurred within the context of reducing over-capacity, as steel producers

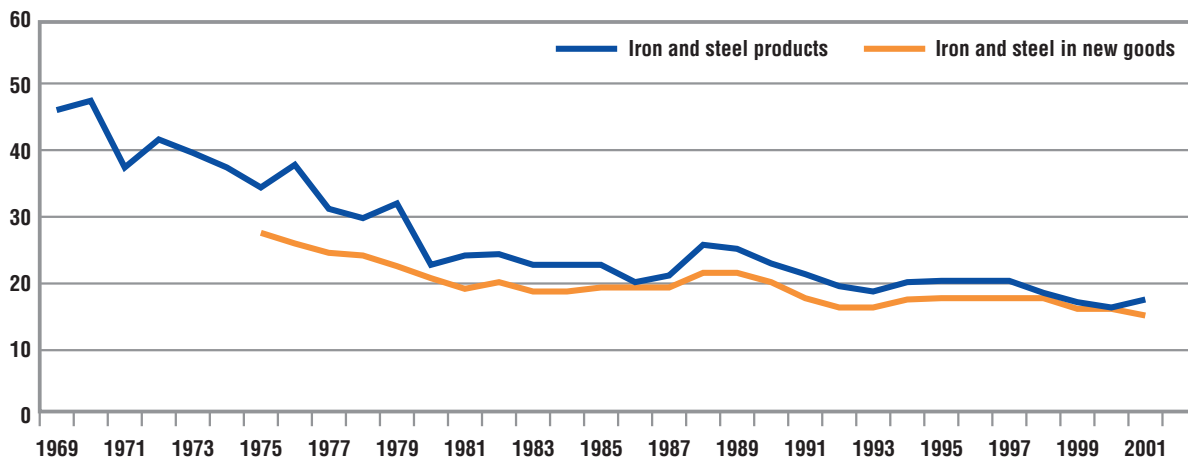

Figure 1.1 Steel intensity of UK economy (tonnes / £million GDP, 1995 values)

have been faced with static demand in most parts of the world. Despite being regarded as one of the most productive steel industries in the world (House of Commons, 2003), the UK steel industry has experienced difficulties in recent years. Corus, which is responsible for 90% of UK steel output, had to cut 12,000 jobs and close two steelworks in 2001, in an attempt to stem the decline in profitability. It is hoped that these changes will help the industry to maintain a fair share of the domestic market, which has seen an increased reliance on imports to meet demand. This trend has been compounded by the general decline in the UK manufacturing sector, and in the short-term exacerbated by the relative strength of the sterling. Global aluminium production capacity was cut by 1.5-2 Mt annually in the early 1990s, and demand as well as production is now growing steadily in the UK.

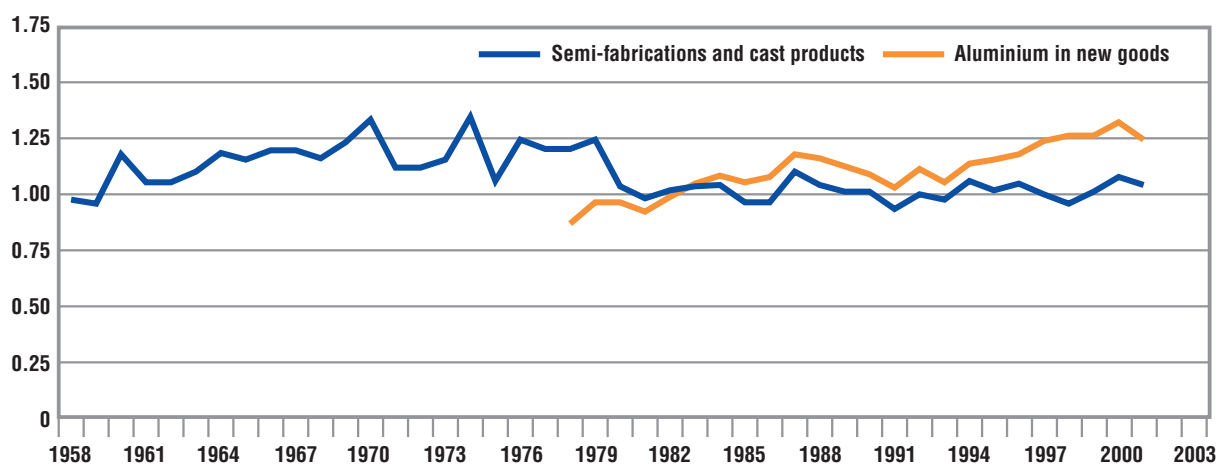

Figure 1.2 Aluminium intensity of UK economy (tonnes / £million GDP, 1995 values)

Figures 1.1 and 1.2 show that the relative economic importance of UK iron and steel production has declined over time, whereas that of aluminium production has increased.

Similarly, UK per capita consumption of these metals has declined in the case of iron and steel, and increased for aluminium. The apparent consumption of crude steel per person in the UK declined from 350 kilograms in the 1970s, to 220 kilograms per person in 2001. The UK per capita consumption is about half the EU average of 410 kg (IISI, 2002). The apparent UK per capita consumption of semi-fabricated and cast aluminium has tripled in the period studied, from 5 kg in 1958 to 15 kg in 2001. The per capita consumption of aluminium products in Europe and the USA is 22 kg and 35 kg respectively (EAA, 2002). These comparatively low figures are thought to be associated primarily with the decline of the UK manufacturing base, and the absence of aluminium as a significant construction material in domestic housing.

2. Material Flow Analysis Methodology

The principle behind MFA is the first law of thermodynamics on the conservation of matter: that matter, i.e. mass or energy, is neither created nor destroyed by any physical transformation (production or consumption) processes. This material balance principle provides a logical basis for physical bookkeeping that is relevant to the economy-environment relationship and for the consistent and comprehensive recording of inputs, outputs and material accumulation.

The models of UK iron/steel and aluminium material flows comprise three main categories of processes. Based on a previous study of material and energy flows through the UK iron and steel sector (Michaelis and Jackson, 2000a, b), three main categories of processes should be distinguished: *production, fabrication and manufacturing*, and *use*. This choice seems to be fairly standard for this kind of analysis (Graedel *et al.*, 2002). Where necessary these processes are further divided into sub-processes, such as production in blast furnaces and basic oxygen furnaces. These process groups describe the transformations from one material category into another, with only material conversions taking place within UK borders being considered.

The material categories for iron and steel are: iron ore; iron and steel home, prompt and end-of-life scrap; pig iron; crude steel; iron and steel industry products; and iron and steel contained in new goods. The material categories for aluminium are: aluminium ore (bauxite); alumina; aluminium home, prompt and end-of-life scrap; unwrought aluminium; aluminium industry products; and aluminium contained in new goods.

Home scrap is defined as scrap produced at the iron and steel works and aluminium plants respectively; this scrap is recycled internally. Prompt scrap, also called new scrap, is generated in the manufacturing of various goods, whereas end-of-life (EOL), or old, scrap is generated when goods become obsolete after use.

There are three ways to increase or decrease material/product stocks, as shown in Figure 2.1. The first is through transformation processes within the boundaries of the UK, which either extract/produce the focal material from upstream materials of different categories or consume/use it by transforming it into downstream materials of different categories. The second way is through transportation processes across the UK borders, i.e. trade. The third way is through disposal and recovery/recycling/reuse processes.

Unlike other MFA studies that use a simple “current account” approach to mass balance, and therefore only account for one or two years’ flows, this MFA features a time series approach which applies the theory of residence time distributions (Danckwerts, 1953) to account for material stocks, primarily of goods in use. This time series feature will therefore help understand how the significant stocks of these metals in use have been built up historically. For upstream material flows, data are assembled from available industrial and governmental statistics on a yearly basis. For downstream material flows (i.e. iron/steel and aluminium content in goods), the time series data is disaggregated into different broad categories of applications, such as construction, transport and packaging.

By matching the time series to the predictions of a dynamic MFA model, estimates are obtained for the quantities of these metals in current use in each of the categories. Furthermore, different life-span distributions have been applied to describe each broad category of goods that enter use in the UK to infer estimates of available EOL waste of these metals. This enables the sensitivity of scrap arisings to the distribution of service lives to be explored, for the first time in MFA. It also provides a way of systematically investigating the level of closure of the data describing the flows of iron/steel and aluminium in the UK.

One important aim of the analysis is to obtain a robust estimate of prompt scrap flow and the generation of old scrap contained in producer and consumer goods leaving the use phase. With enough information about these flows and the changes of the scrap stock it is possible to assess the level of closure of the UK iron/steel and aluminium cycles, i.e.

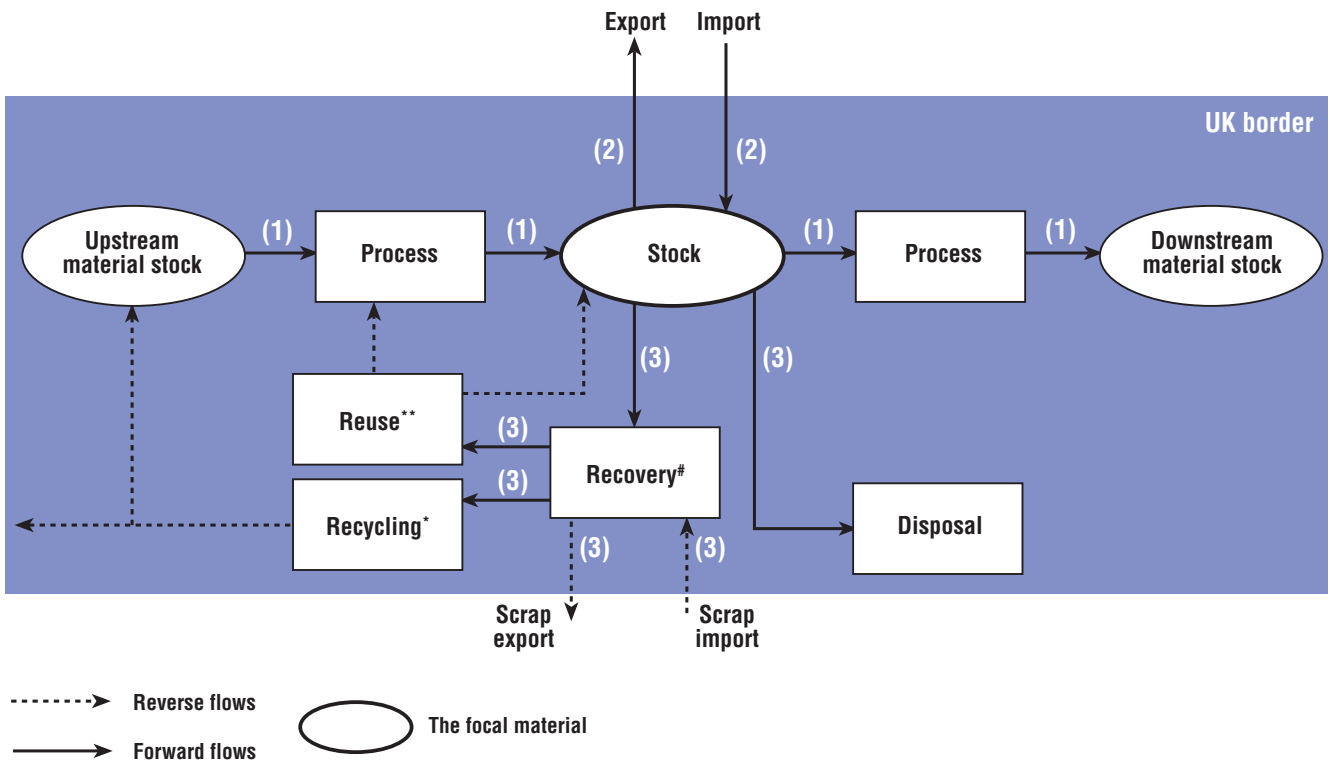

In the figure:

- (1) denotes flows involved in transformation processes, excluding the use of and emissions to air
- (2) denotes flows involved in transportation processes
- (3) denotes flows involved in recovery, recycling /reuse and disposal

"Recovery" refers to activities where used products or materials are collected/sorted and ready to be reused or recycled. The recovered materials can also be imported to be reused/recycled overseas or imported from abroad.

** "Reuse" includes two types of activities. One type refers to a used product returned to be refurbished and ready to be used, so that the refurbished product still belongs to the same category of stock without further processing. Another type refers to a used product, which is disassembled with some of its components or parts taken for refurbishing while others are contaminated or worn so that they must be reprocessed or treated as waste. Components which are reused must be remanufactured by re-assembly with other components into a remanufactured product.

* "Recycling" refers to activities where a product or part of its components cannot be reused and have to be reprocessed back to one of the upstream material stocks.

Figure 2.1 System modelling for the MFA

the recycling rates of these metals. Scrap from the stock of prompt and EOL scrap is recycled domestically, exported, or lost from the economic system, typically through landfill. If scrap is exported, it is assumed that it will be recycled abroad and is counted as recovered rather than lost. The UK recycling rate that is used in this study, therefore, is defined as the yearly consumption of prompt and EOL scrap in UK iron/steel and aluminium production, minus scrap imports, plus scrap exports, divided by the yearly release of UK prompt and EOL scrap:

$$\text{Recycling rate} = \frac{\text{Yearly UK prompt and EOL scrap consumption} - \text{imports} + \text{exports}}{\text{Yearly arisings of prompt and EOL scrap in the UK}}$$

In order to estimate the generation of EOL scrap, the time delay of goods in use has to be taken into account. The estimated EOL scrap arisings can then be compared to documented recycling rates in order to assess the level of closure of these materials cycles in the UK; that is, how much scrap is returned to the production and use system and how much is lost. Since documented scrap consumption and trade data do not discriminate between prompt and EOL scrap, the system has to include production and consumption of prompt scrap as well. The flow of iron/steel and aluminium industry products into UK manufacturing is divided into different sectors. Part of the deliveries is turned into prompt scrap during manufacturing and fabrication of goods according to the prompt scrap rate of each sector. This rate was set as a percentage of the sectors' material consumption, based on a literature review and discussions with industry. The remaining

iron/steel and aluminium is then incorporated into goods and either exported or delivered to use in the UK together with imported goods. Lifespans for categories of goods in the various sectors were compiled from a range of data sources. These lifespans will determine when the metals will emerge from the use and consumption phase as old scrap.

In the study three lifespan distributions have been used for each goods category to yield the release of EOL scrap: no distribution, i.e. a fixed number of years; a Weibull distribution; and a lognormal distribution. However, due to a lack of information on the actual distributions of the life spans, only information on the average lifespan figures has been obtained for each goods category. Consequently, the Weibull and lognormal distribution do not reflect any real lifespan distribution data, but give a general distribution of the average lifespan figures that have been collected for each goods sector. In the case where minimum and maximum lifespan values for a goods sector have been available, a corresponding shape of the curve has been chosen to model this.

3. Material Flow Analysis Findings

Iron and Steel

The system model of iron and steel is shown in Figure 3.1. This is the basic overview of iron and steel in the UK, showing trade in these materials (arrows across the UK border), production by the iron and steel industry, and consumption by wider society as well as waste disposal and recycling. To this diagram can then be added the actual mass of the current flows and stocks of these materials (Figure 3.4) and the current value of these flows and stocks (Figure 5.5). An important feature of the supply chain for both iron and steel and aluminium is the fact that a considerable amount of scrap is fed back into the system as secondary raw material. In fact, iron and steel is the most recycled material in the world, with more than 435 million tonnes (Mt) recycled in 2001 (IISI, 2002). For this reason the iron and steel supply chain is sometimes also called the iron and steel cycle (Birat *et al.*, 1999).

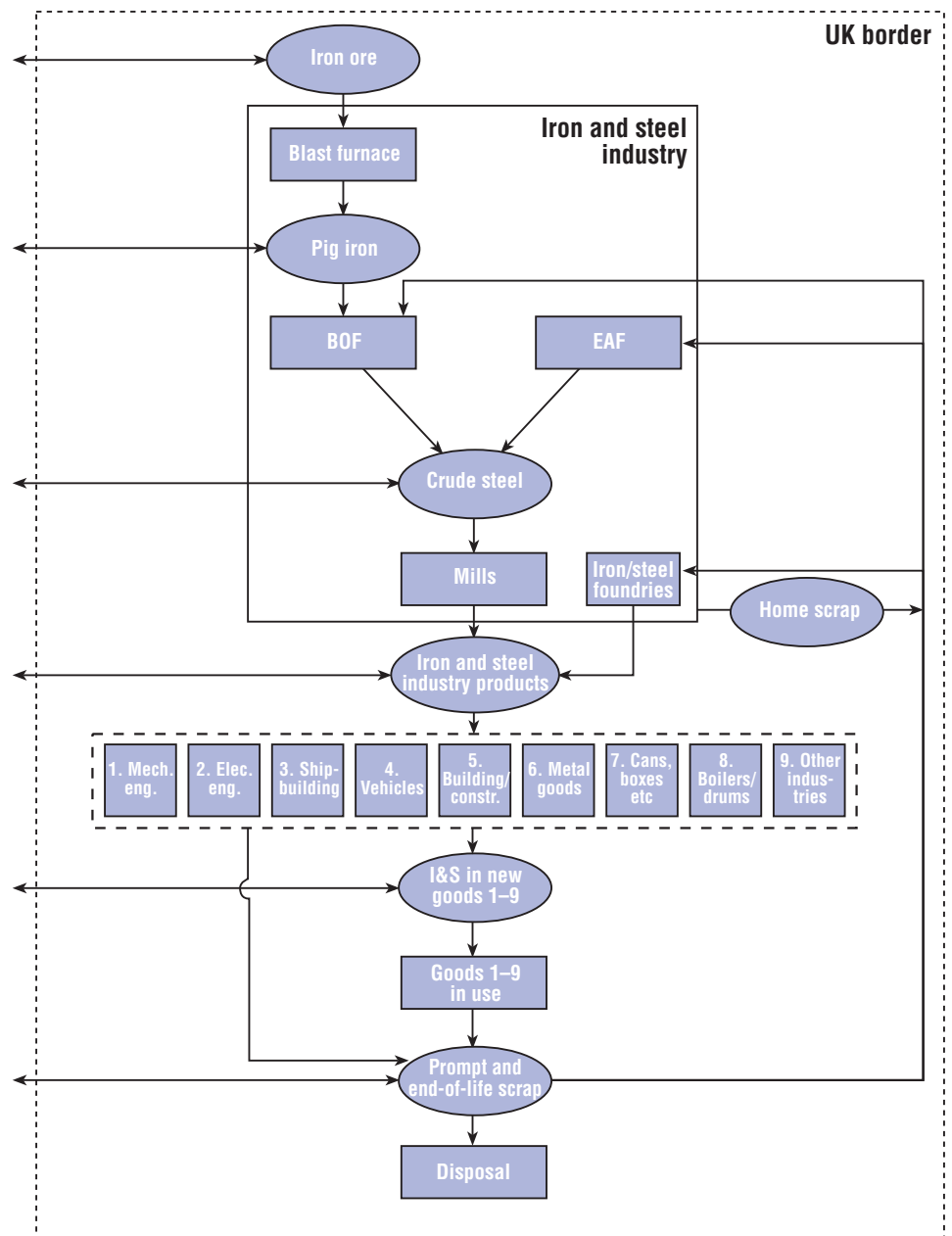
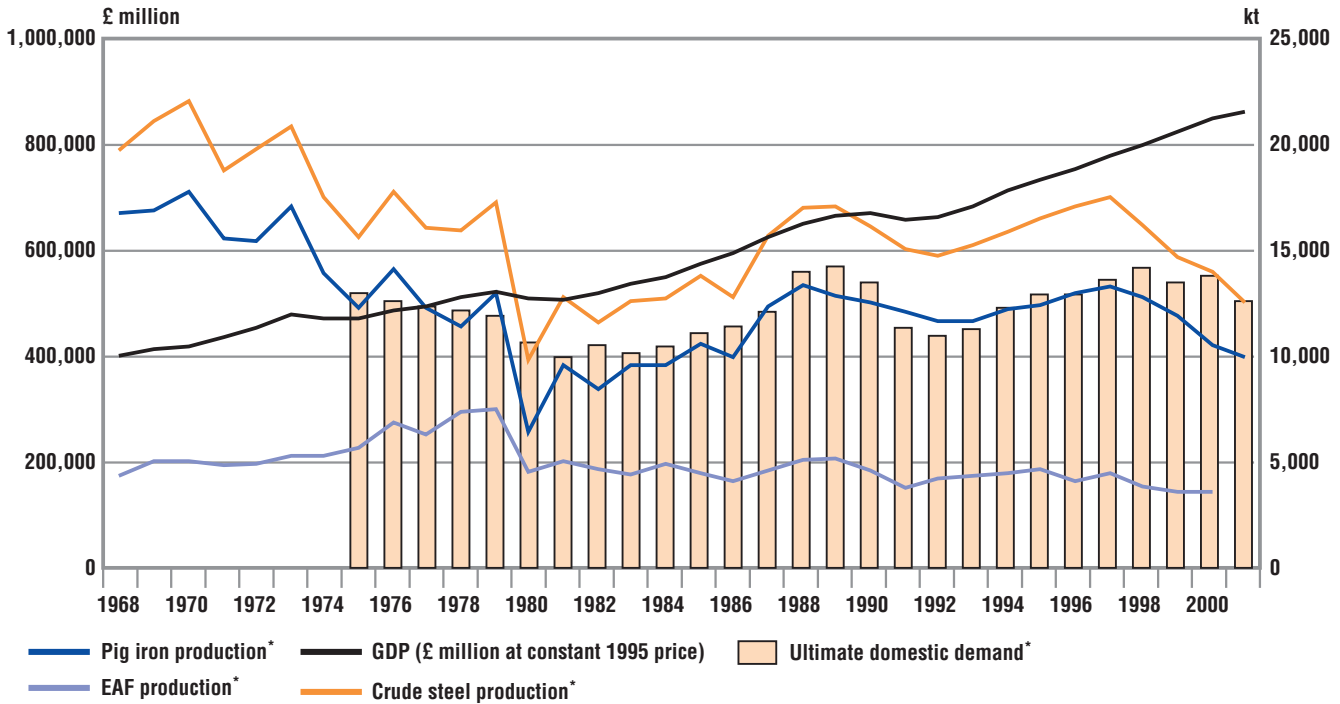

Figure 3.1 System overview of iron and steel flows in the UK



* series scaled to the right hand axis

Figure 3.2
Iron and steel production
and GDP growth

The iron/steel time series MFA found that the ultimate demand of iron and steel (i.e. iron/steel contained in goods and applications) has been fairly stable over the years. In terms of sources of the flows, currently over half of the goods containing iron and steel needed for the domestic market are imported. The significance of imported goods in meeting domestic needs for iron and steel does not mean low domestic production. Around half of the upstream production (i.e. producing iron/steel products and goods containing the metal) in the iron/steel supply chain is exported.

When comparing the current and past situation in the upstream iron and steel supply chain, there was higher production with relatively smaller amounts of trade in the 1960s and 1970s. This implies that domestic production was able to meet most of the downstream domestic demand. However, the upstream iron/steel supply chain currently imports around 40-50% of iron/steel products to support demand in downstream goods manufacturing. Up to 40% of goods containing iron and steel produced in the UK is exported to help other countries satisfy their domestic demand for these goods. Thus there have been significant shifts in the role of domestic production and trade in the supply chain over the years.

Accompanying these material flows are stocks of different material categories including both manufacturing and industrial stocks and stocks of products in use, together with prompt and end-of-life (EOL) scrap arisings. The study inferred that there are currently about 11 Mt per year of prompt and EOL iron and steel scrap arisings. About 70% of this scrap is recovered, then either reused/recycled domestically or exported. Around 30% is lost from the economy, of which two-thirds ends up in landfill.

Over the past 30 years, the UK has experienced a decline in secondary iron and steel production, that is, steel production in the electric arc furnace (EAF) route using primarily ferrous scrap as an input. The integrated route via the blast furnace and the basic oxygen furnace (BF/BOF) uses primarily virgin inputs in its steel production. Currently, the EAF steel making route accounts for 25% of total UK crude steel output, while it used to contribute 35-40% in the 1970s and 1980s. This change has been associated with increasing exports of scrap – currently over half of the recovered iron and steel scrap is exported.

Figure 3.2 shows the decline in both pig iron and crude steel production between 1968 and 2001 in comparison with the increase in GDP. Pig iron and crude steel production decreased by an annual rate of 1.5% and 1.22% respectively, while GDP grew by an average annual 2.22% over the past 34 years. Figure 3.2 also shows the ultimate domestic demand for iron and steel materials, namely iron and steel contained in goods, and the contribution of iron and steel scrap recycling to crude steel production.

The ultimate domestic demand declined slightly from around 13 Mt in 1968 to 12 Mt in 2001, an average annual rate of decrease of 0.09%. UK demand for iron and steel

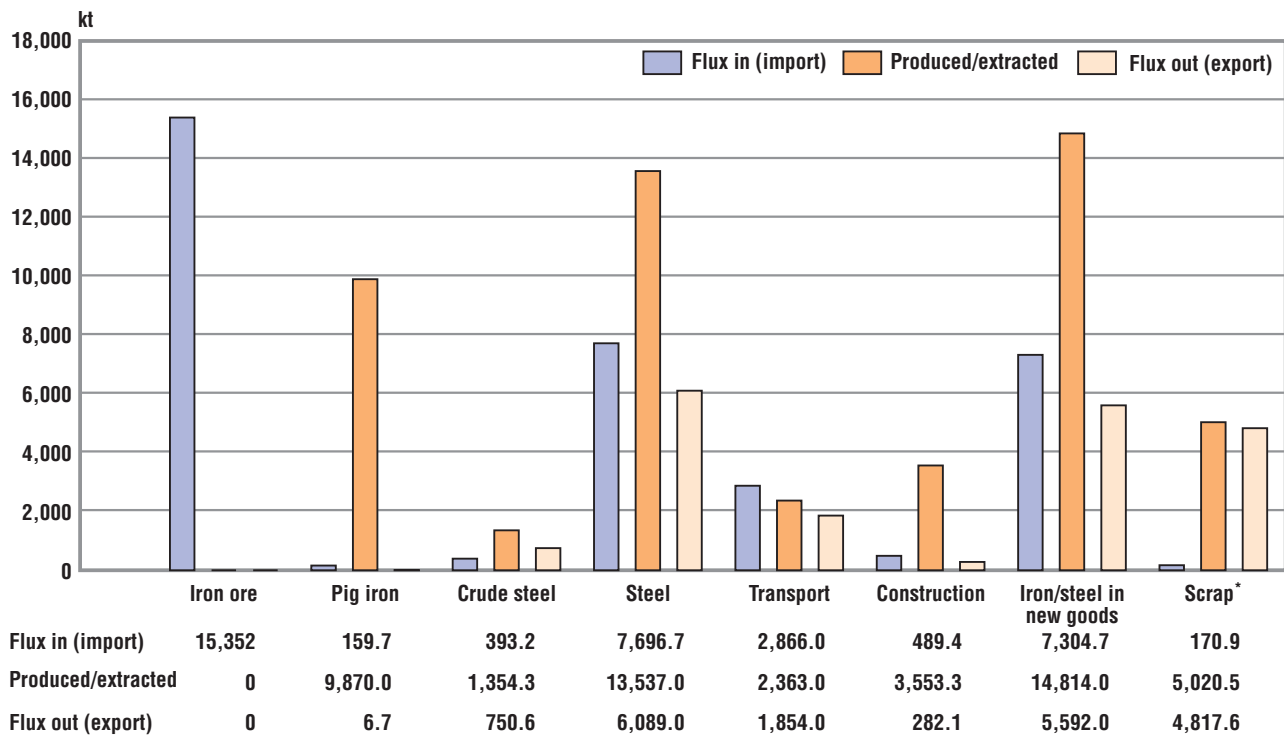

*produced/extracted for scrap refers to consumption of scrap (home, prompt and EOL scrap) at steel producers.

Figure 3.3
Iron and steel material flows
in the UK, 2001

therefore seems to have become effectively decoupled from economic growth. Output from the EAF route decreased by an average annual rate of 0.79%, from 4 Mt in 1968 to 3 Mt in 2001. However, the contribution of EAF to total crude steel output in the country was 22% in 1968 and 25% in 2001, varying between 20% and 40% over the whole period.

Figure 3.3 illustrates current (2001) material flows in the UK iron and steel supply chain. In the upstream production of crude steel, domestic demand is supplied primarily by domestic production. Further downstream in the supply chain, imports and exports are much more significant. Figure 3.3 shows these features for the two main iron and steel application sectors, transport and construction. In the transport sector, imports are larger than production or export flows. By contrast, in the construction sector, domestic production dominates and imports play little role in meeting domestic demand. Overall, domestic production of iron and steel contained in goods is higher than both imports and exports. There are scrap imports but much larger exports of scrap, meaning that the UK recovered more iron and steel scrap than that used in EAF production.

Figure 3.4 shows an overview of all the flows of iron and steel for the year 2001. All iron ore used in iron and steel production in 2001 was imported, as there is no longer any mining of iron ore in the UK. Most of the pig iron used in production is produced domestically; only a very small part is imported. In 2001, about 75% of UK produced crude steel came from the integrated route (BF/BOFs) and 25% from EAFs. Further down the chain it appears that almost half of the iron and steel products produced in the UK are exported and that imports of iron and steel products are just as high as exports. This implies that a large part of the domestically produced iron and steel products is different from those required by UK goods manufacturers and fabricators, or that it is financially more attractive for UK iron and steel producers to export and goods manufacturers to import iron and steel products.

About 15 Mt of iron and steel products were delivered to UK goods manufacturers and fabricators in 2001. Most of this iron and steel went into building and construction followed by other industries, mechanical engineering and vehicles. These four sectors currently consume 80% of the total deliveries of iron and steel products in the UK. Just less than 10% of the total iron and steel deliveries to UK manufacturers was turned into prompt scrap and recycled back into the system. Out of the iron and steel in goods produced in the UK, about 40% was exported and the rest was delivered to use in the UK. There is a substantial amount of iron and steel in goods imported to the UK: in 2001 more than 7 Mt of iron and steel in goods were imported.

About 10 Mt of EOL scrap were released in 2001. Together with available prompt scrap arisings this makes up more than 11 Mt scrap. Of this, 4.8 Mt were exported and recycled abroad whereas 3.5 Mt were recovered and recycled domestically. A further 2 Mt

Note: flows may not balance each other in this chart due to industrial and manufacturing stocks held by businesses which are not included here.

Figure 3.4 System overview of UK iron and steel flows in 2001 (thousand tonnes)

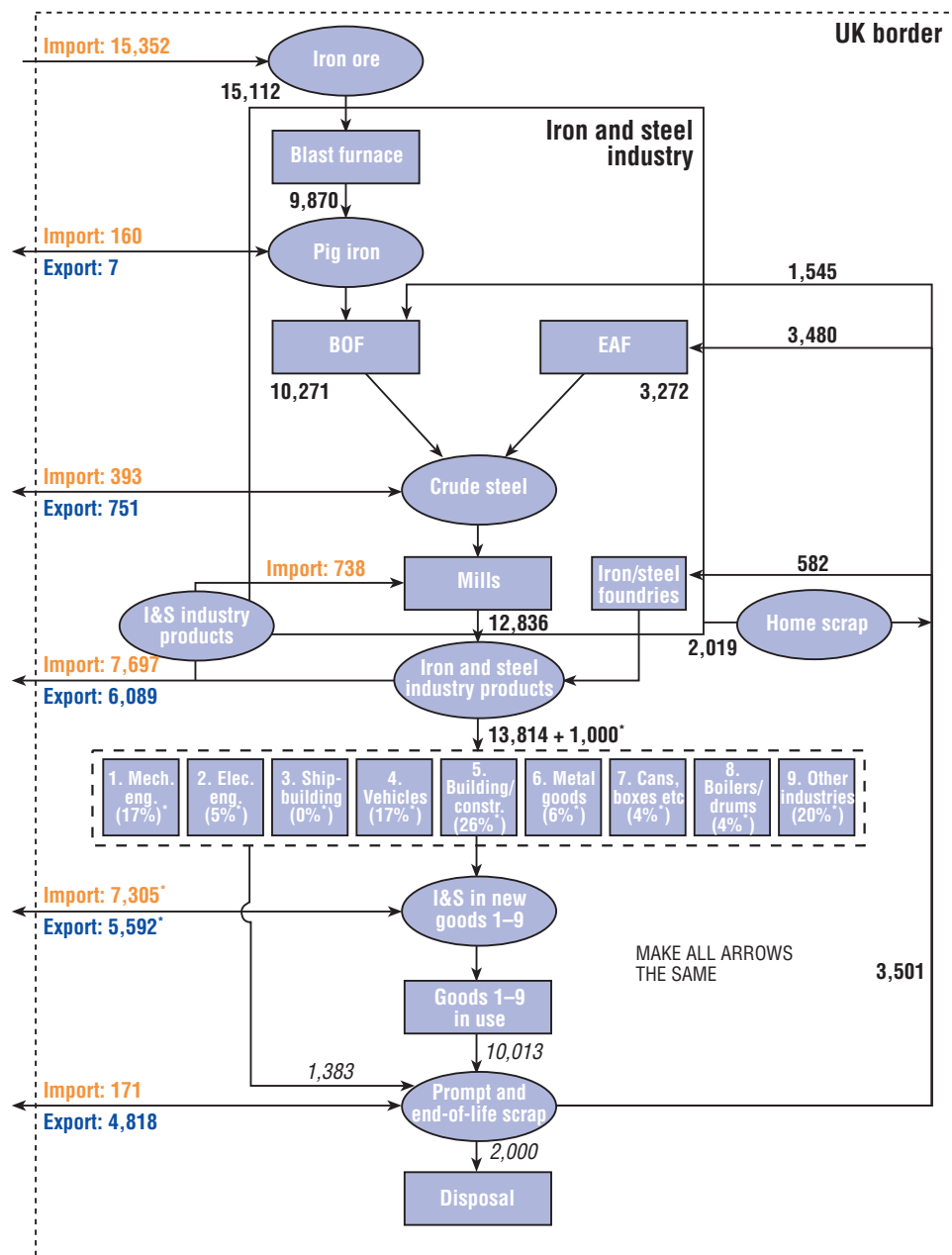

ended up in landfill. The recovery of iron and steel scrap arisings in the UK therefore seems to be working relatively well in that about 70% of the scrap arisings is being recovered and recycled (although not domestically). However, the flow diagram suggests there is still scope for increasing the quantity of UK scrap iron and steel that is recycled.

Aluminium

The system model for aluminium is shown in Figure 3.5. This is the basic overview of aluminium in the UK, showing trade in these materials (arrows across the UK border), production by the aluminium industry, and consumption by wider society as well as waste disposal and recycling. To this diagram can then be added the actual mass of the current flows and stocks of these materials (Figure 3.8) and the current value of these flows and stocks (Figure 5.6). Today in the UK, the aluminium story begins at the primary smelter stage as all of the alumina used is imported. Although there was alumina production from bauxite in the UK before 2000, none of the alumina produced was put into primary aluminium production.

The aluminium time series MFA found that the ultimate demand for aluminium has grown fairly steadily over the past 40 years. In terms of sources of the flows, currently around 60-80% of the aluminium contained in goods in use in the UK comes from imports. The significance of imported goods in meeting domestic needs does not mean

Note: No alumina produced in the UK in recent years has been used for the production of primary aluminium. Instead it has been used for refractory materials, abrasives, etc.

* Material and process not used for aluminium production in the UK since 2001

Figure 3.5 System overview of aluminium flows in the UK

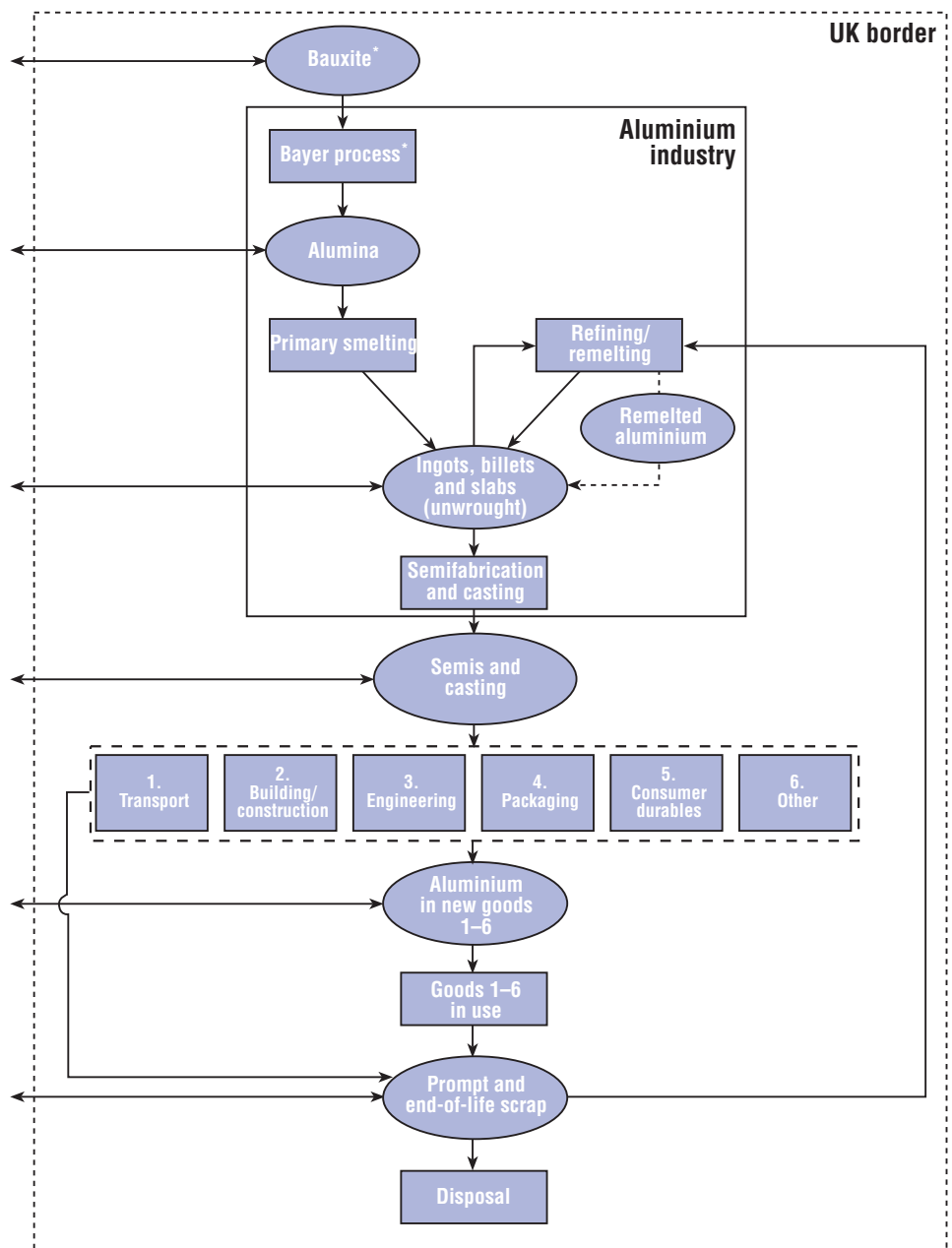

low domestic production. Around half of the upstream production (i.e. aluminium products and goods containing the metal) in the supply chain is exported.

Unlike the developments over time in the iron and steel supply chain, the upstream aluminium supply chain has seen an increase in production as well as in trade over the past two decades. The aluminium supply chain depends on imported aluminium products to fulfil 40-50% of demands in downstream goods manufacturing. On the other hand, 60-70% of goods containing aluminium produced in the UK is exported.

Accompanying these material flows are stocks of different material categories, including both manufacturing and industrial stocks and stocks of products in use together with prompt and end-of-life (EOL) scrap arisings. The study indicates that currently about 700,000 tonnes per year of prompt and EOL aluminium scrap are released from use. Like iron and steel, about 70-80% of this scrap is recovered, either through domestic or overseas reuse/recycling. Less than 30% is lost from the economy, of which 80% ends up in landfill.

Over the past 40 years, the UK has seen an increase in the output from the aluminium recycling industry. Recycling is done by refiners, which use mainly old scrap, and remelters, which rely on predominantly prompt scrap. Secondary unwrought aluminium production has remained fairly stable, currently accounting for 40-50% of total unwrought aluminium output in the UK, whilst wrought aluminium production, using predominantly prompt scrap, showed remarkable growth. Despite increasing aluminium recycling, around 40% of recovered aluminium scrap is currently exported.

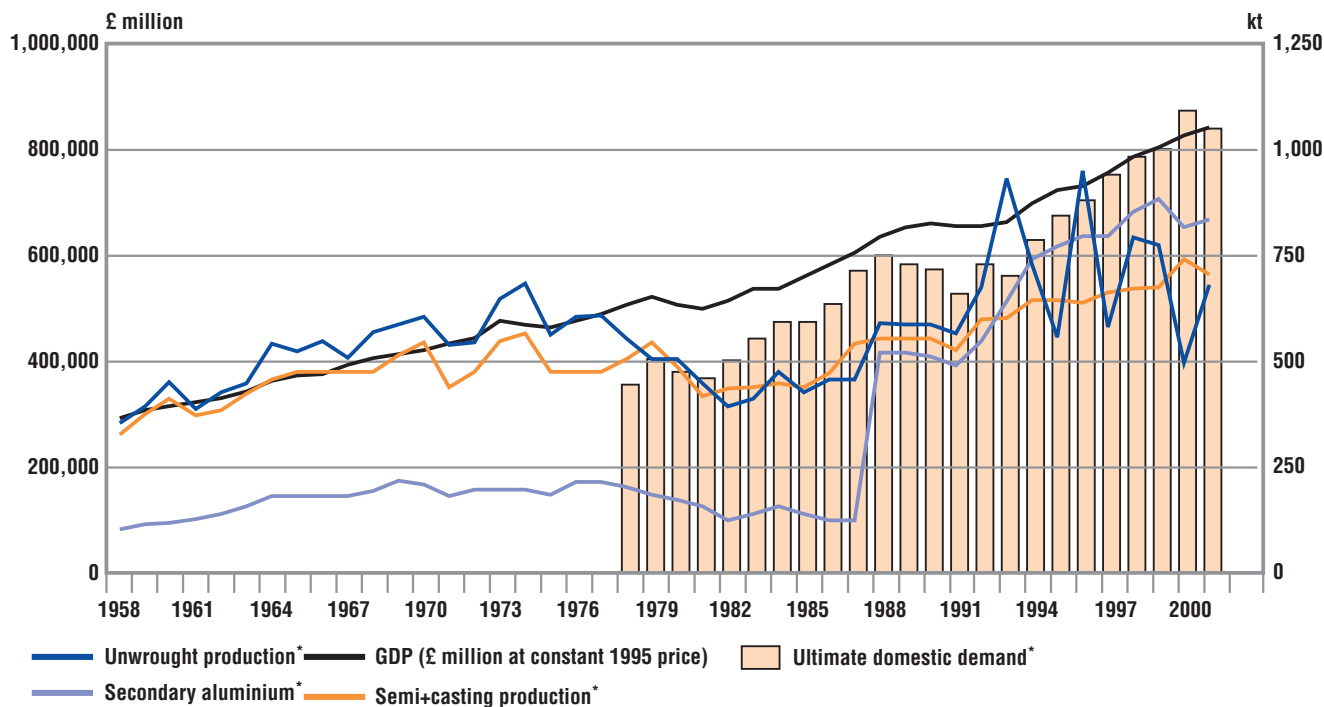

* series scaled to the right hand axis. Secondary aluminium production refers to aluminium scrap (home, prompt and EOL scrap) consumption in both secondary unwrought production and wrought products production predominantly using aluminium new scrap.

Figure 3.6 Aluminium production and GDP growth.

Note: as alumina production for the aluminium industry in the UK ceased in 2001, bauxite and alumina material flows are not shown in the chart. For scrap, produced/extracted refers to scrap consumption in aluminium production both in unwrought and wrought products.

Figure 3.7 Current aluminium material flows in the UK: 2001

Figure 3.6 shows UK GDP growth and the increase in both unwrought and semi-fabrications/casting aluminium production over the period 1958-2001. The data for unwrought aluminium production show large fluctuations in the 1990s. However, on average unwrought and semi/casting production increased by 1.57% and 1.78% annually, while GDP increased on average by 2.5% in the same time period. Figure 3.6 also shows the time series for ultimate domestic demand of aluminium, i.e. aluminium contained in goods, and secondary aluminium production. The UK experienced an increase in demand for aluminium in goods over the last 24 years, from 400 thousand tonnes (kt) in 1978 to 1 million tonnes (Mt) in 2001, corresponding to an annual average growth of 3.69%. Unlike iron and steel demand, therefore, which in the UK is effectively decoupled from economic growth, aluminium demand is growing faster than GDP. The consumption of recycled aluminium also increased at an annual average rate of 4.92% in upstream aluminium production. This increase has largely been due to expansion of new scrap recycling (i.e wrought aluminium production predominantly using new scrap) by aluminium remelters.

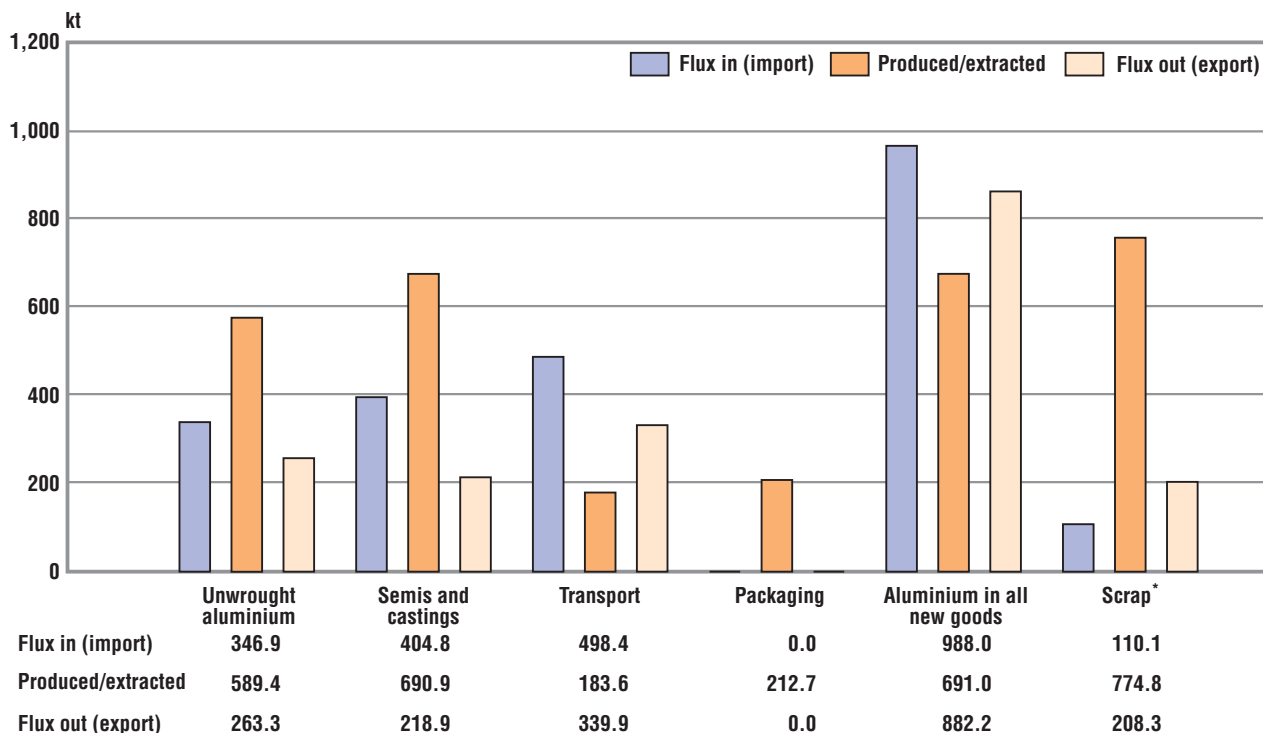

* World Bureau of Metal Statistics
 ** 2000 figures
 # Alfred
 Scrap arisings are modelled, tonnages for disposal are based on Defra data.
 Note: flows may not balance each other across different processes and material categories due to the delays caused by manufacturing and industrial stock holding practices.

Figure 3.8
 System overview of UK aluminium flows in 2001 (tonnes)

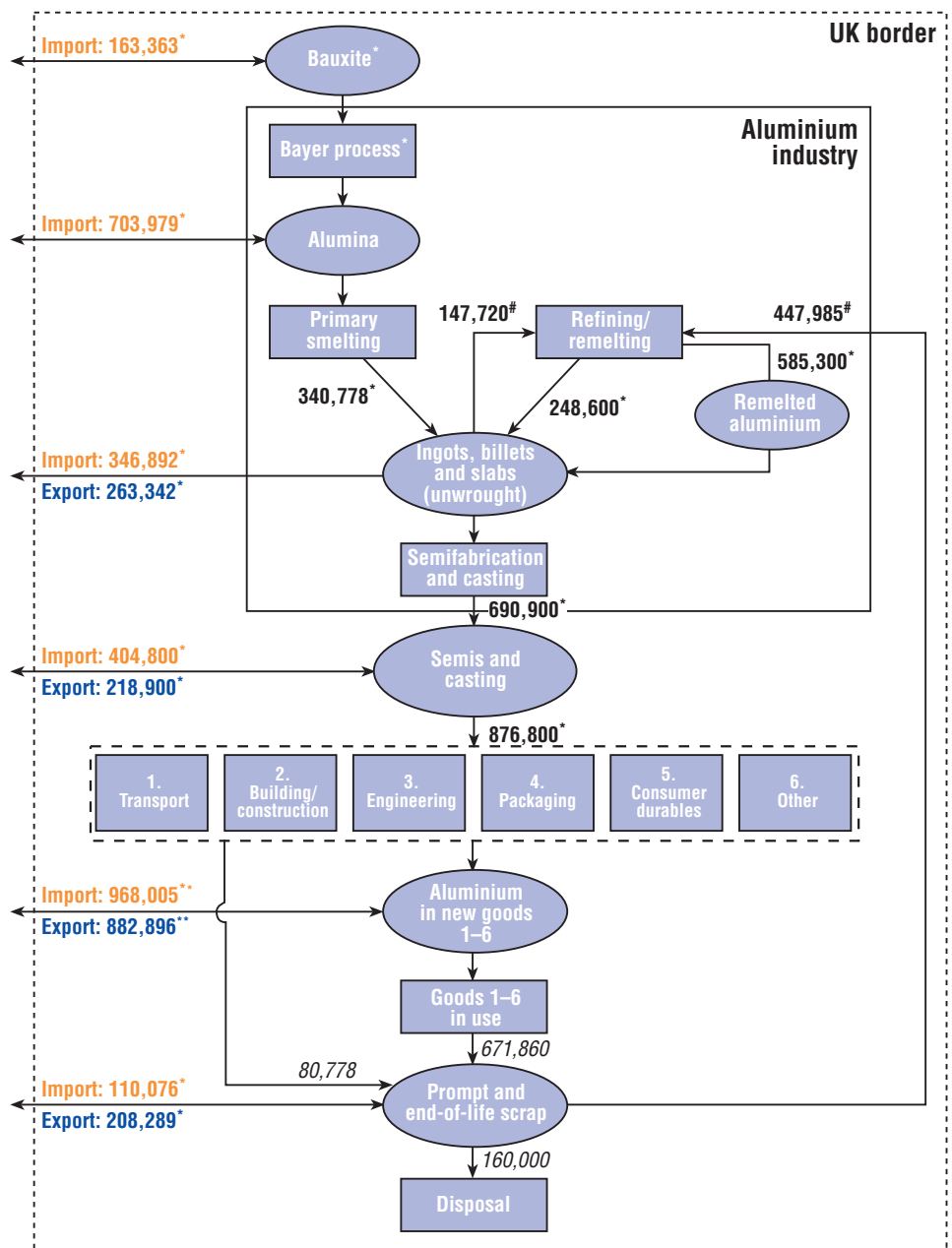

Figure 3.7 illustrates current material flows in the UK aluminium supply. There has been more trade across the whole of the aluminium supply chain than is the case for iron and steel. As an illustration, Figure 3.7 shows the material flows of the two main aluminium application sectors, transport and packaging. In the transport sector, imports and exports are both very much larger than production of goods for domestic use. For the packaging sector, no actual trade data were available, but due to its characteristics (e.g. the short service life of packaging goods), no net trade was assumed in this sector. Overall, UK aluminium demand is predominantly met through imported finished goods. The figure also shows high aluminium scrap consumption in both unwrought and wrought aluminium production.

Figure 3.8 shows an overview of all the flows of aluminium for the year 2001. All alumina used in primary aluminium production in 2001 was imported, as alumina production stopped in the UK in 2000. There was however still around 160 kt of imported bauxite, which were destined for export. In 2001, about 340 kt of primary aluminium and 830 kt of remelted aluminium were produced in the UK. Further down the chain, one-third of the aluminium semis and castings produced in the UK were exported. Imports of aluminium semis and castings products were about twice the size of exports.

About 900 kt of aluminium semis and castings were delivered to UK goods manufacturers and fabricators in 2001. Most of this aluminium went into construction, followed by the transport and packaging sectors. These three sectors currently consume more than 70% of the total deliveries of aluminium semis and castings in the UK. Just

less than 10% of the total aluminium deliveries to UK manufacturers emerged as prompt scrap and was recycled back into the system.

There is a substantial amount of aluminium in goods imported into and exported from the UK. In 2001, more than 800 kt of aluminium contained in goods were exported from the UK, and almost 1 Mt of aluminium in goods were imported. This massive trade in goods containing aluminium is the result of an increasing trend over the last ten years. About 620 kt of EOL scrap were released in 2001. Together with available prompt scrap arisings this makes up about 700 kt of available scrap. Of this scrap, 200 kt were exported and recycled abroad, and 450 kt were recovered and recycled domestically. A further 160 kt ended up in landfill. The recovery of aluminium scrap arising in the UK therefore seems to be working relatively well, in that more than 70% of the scrap arisings is being recovered and recycled. However, there is still scope for increasing the quantity of UK scrap aluminium that is recycled.

4. Value Chain Analysis Methodology

In its most common application, value chain analysis is a strategic management or cost accounting tool used to diagnose and enhance a company's competitive advantage. The analysis does this through a breakdown of an organisation's strategic activities (so called value activities); an examination of their costs; and the streamlining and coordination of the linkages of those activities within the 'value chain'. This exercise can enhance the efficiency of a company's internal operations and aid decisions concerning investments and expansions. Competitive advantage stems not only from the value activities in themselves, but also from the way they are related to each other through linkages within the value chain. (Porter, 1985).

Value chain analysis as applied in this project starts with the explicit recognition that the stocks and flows of iron/steel and aluminium have associated economic values. As materials are transformed and pass along a chain of production, fabrication, use/consumption and reuse or disposal, the value of the materials is either enhanced or reduced. Note that 'value' in this project refers only to actual monetary values of materials, and does not attempt to put a value on any positive or negative externalities.

Resource Productivity and Efficiency

Many current environmental problems are rooted in the size of society's material throughput, suggesting that a *decoupling* of economic growth and resource flows is needed to reduce environmental impacts while improving quality of life. Such a decoupling hinges on improvements in resource productivity and efficiency, defined broadly as doing more with less. Decoupling can be either relative or absolute. Relative decoupling means that productivity improvements – fewer inputs required per unit of output – have been realised but total inputs continue to increase as output increases. Absolute decoupling refers to the situation in which there is an overall reduction in required inputs, whether through productivity improvements or through a decrease in outputs, or a combination of the two.

This report distinguishes between *resource productivity* and *resource efficiency*. Resource efficiency is measured as a basic ratio of two physical variables. Therefore material efficiency can be measured as a ratio between material output, M_o , and material input, M_i , such as useful material output per total material input:

$$M_o/M_i = \text{material efficiency}$$

Other physical ratios of interest for the issue being studied, such as useful material output produced per amount of waste or pollution generated, or useful output per input of energy, might also be used.

Productivity, however, is used in relation to some kind of welfare outcome. In economic terms this might be economic output, so that material productivity would be the economic output, Y_o , per unit of natural resource input:

$$Y_o/M_i = \text{material productivity}$$

or economic output per amount of pollution or waste generated, or per input of energy (energy productivity).

It is this latter definition of resource productivity that is advocated in the Performance Innovation Unit's report on resource productivity (PIU, 2001), as a measure of the effectiveness with which the economy generates added value from the use of nature, and which can therefore tell whether economic growth is decoupling from natural resource

use. This definition is also analogous to the concept of labour productivity, which is measured as GDP or value added per worker or per hours worked, and which is used by the Treasury as a key indicator of UK productivity. Two labour productivity indicators will be used in the analysis: economic labour productivity, which is value added per worker, and material labour productivity, which is material output per worker.

Resource productivity as measured in this way is therefore a generic indicator for measuring progress towards a less material intensive economy. By combining material and economic time series data for the steel and aluminium industries, the project has examined resource productivity and efficiency trends in the steel and aluminium industries. Specifically, it has attempted to answer the following questions:

- Are the steel and aluminium industries improving their material efficiency, that is, are they creating more useful material output with fewer material inputs;
- Are the steel and aluminium industries improving their energy efficiency, that is, are they creating more useful material output with less use of energy;
- Are the steel and aluminium industries improving their material productivity, that is, are they creating more value with fewer material inputs;
- Are the steel and aluminium industries improving their energy productivity, that is, are they creating more value with less use of energy; and
- Is any relative or absolute decoupling observable?

Value Chain Mapping

As materials are transformed and pass along a chain of production, fabrication, consumption, and disposal or reuse, the value of the materials is either enhanced or reduced. One aim of the project was to identify and map the magnitude of these changes in values. As a first step in mapping the value chain, a diagrammatic overview of the steel and aluminium industries is created, building on Figures 3.1 and 3.5, with respect to flows of principal materials through the productive chain and their values; flows of inputs and their values; and flows of outputs and their values. Then, values are established for the principal material categories from a range of data sources.

Figures 4.1 and 4.2 shows these overview diagrams for the UK steel and aluminium industries respectively. The diagrams and their associated nomenclature take account of the fact that broad material categories, such as crude steel or unwrought aluminium, have different values depending on the quality of the material; its source; and its destination. In the diagrams, materials are further detailed with the help of letters denoting whether the material is an input to a process, or an output from a process. On the input side, *e* denotes energy inputs; *Mn* ancillary materials; *Ma* atmospheric materials; *Mi* imported material. For outputs, a distinction is made between materials destined for the domestic market (*Md*), for export (*Mx*), for waste disposal (*Mw*), or whether the outputs are residual materials (*Mr*), such as wastes, emissions, or valuable by-products. While iron and steel and aluminium scraps are clearly examples of such valuable residual materials, this material category is included among the main material categories as it is of specific interest for the project.

The first number attached to the material denotes the *process*: in the case of inputs (materials denoted by *a*, *e*, *i*, or *n*), the process that the material is going into, or in the case of outputs (*d*, *r*, or *x*), the process from which the material emerges. The second number denotes the material. Therefore, *IM1i* in Figure 4.1 denotes imports of material 1, iron ore, into process 1, the blast furnace, and *IP1i* denotes the price of those same imports. Further down, *M6x* is material 6, scrap, destined for export, although the process from which it stems is undefined as available trade statistics do not contain that level of detail. Scrap, M6, illustrates well the point about broad material categories having different values: scrap from process 5 is old scrap, whereas scrap from process 4 is prompt scrap, and scrap from process 3 is home scrap. Therefore, these three categories have different values, denoted by *5P6d*, *4P6d*, and *3P6d*.

The results of the Value Chain Analysis are reported in Section 5.

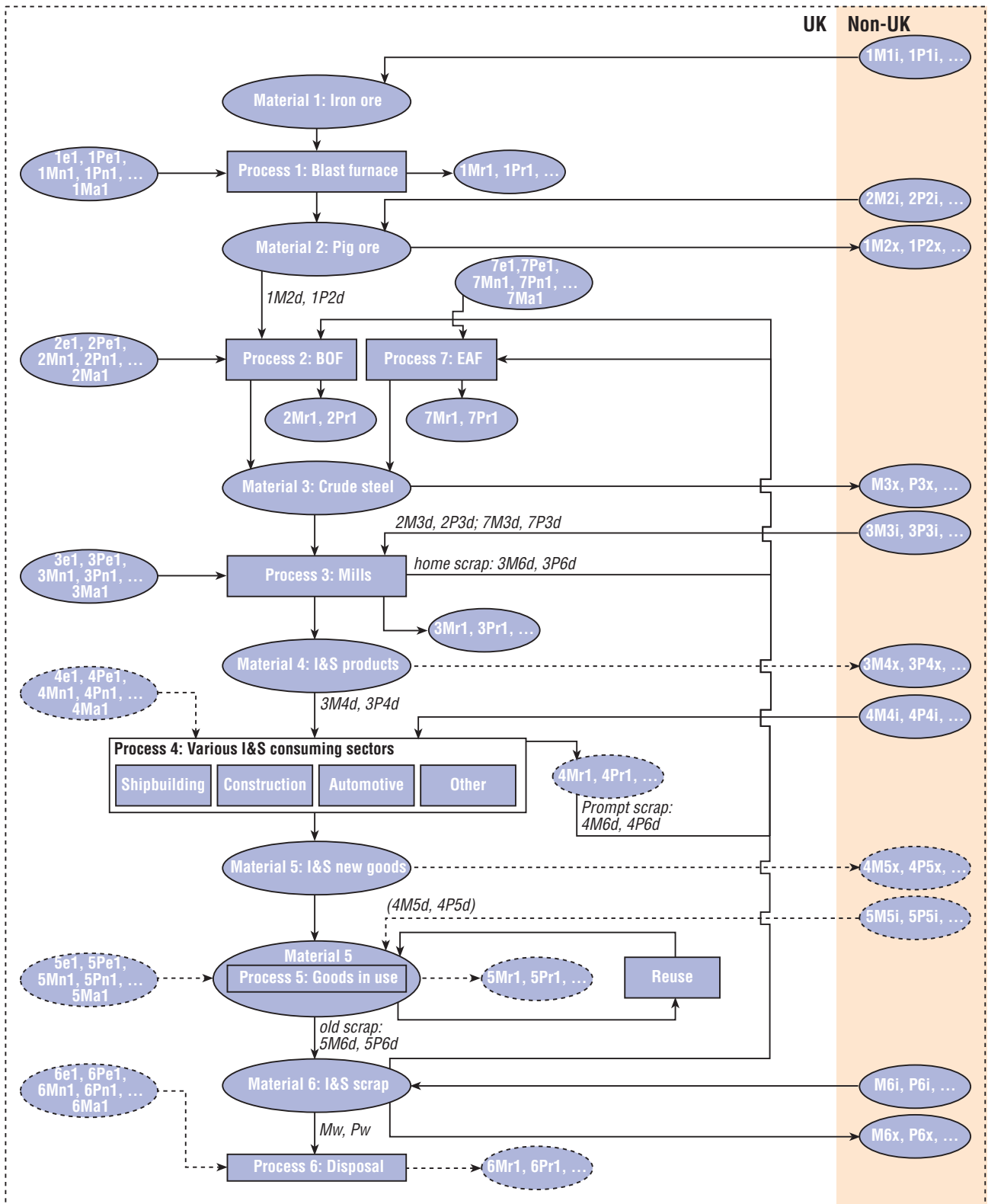

Figure 4.1
Iron and steel material and value flow overview

Packaging Waste

The UK system of implementation of the EU Directive on Packaging and Packaging Waste (EC/94/62) is also examined. The system of Packaging Recovery Notes (PRNs), the tradable mechanism used to implement the Directive in the UK, is explained, and the costs, mechanisms and targets are analysed in relation to steel and aluminium packaging waste in Section 6, which also contains a number of recommendations of relevance for public policy.

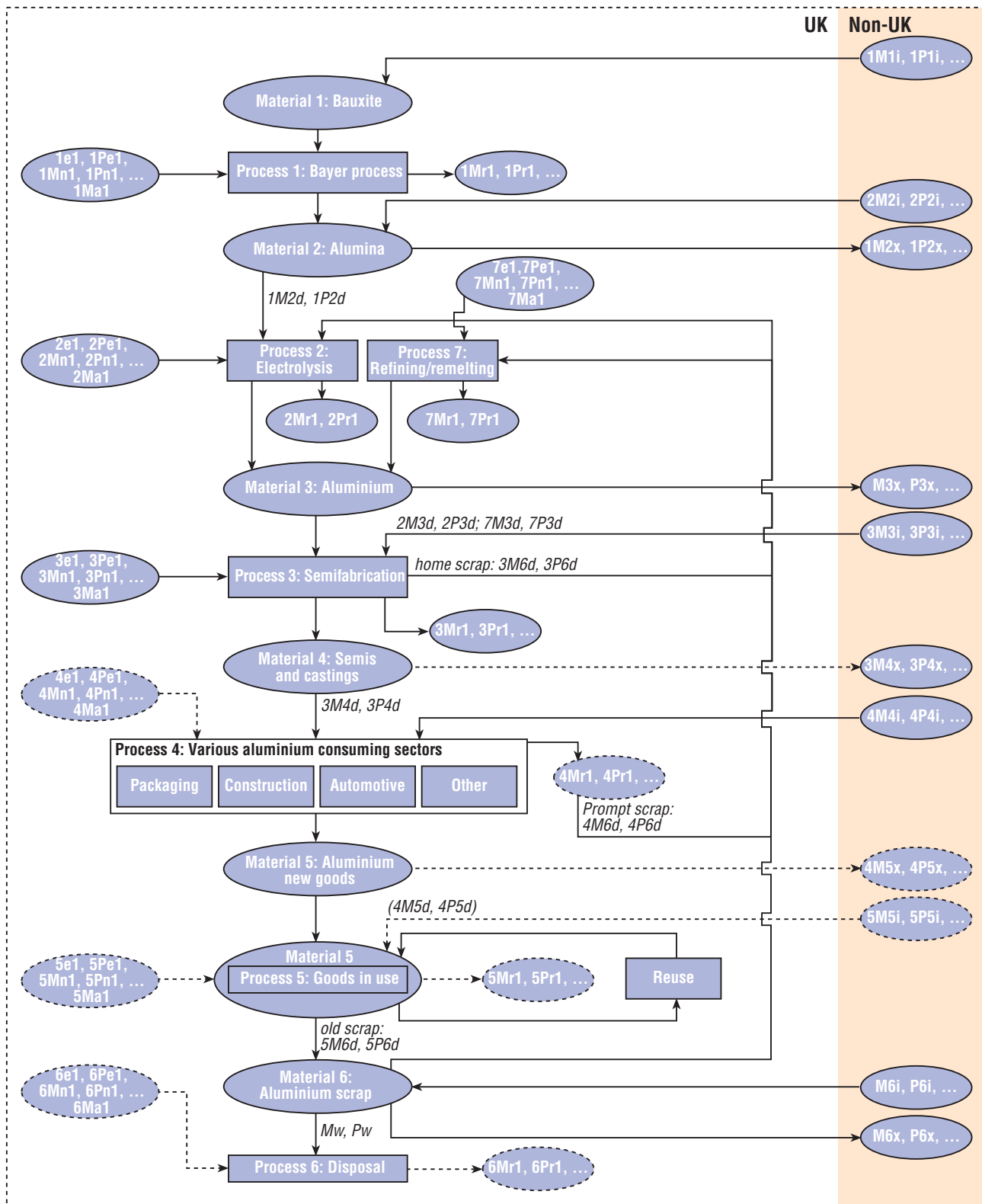

Figure 4.2
Aluminium material and value flow
overview

5. Value Chain Analysis Findings

Resource Productivity and Efficiency

Iron and Steel

Over the time period studied, the UK iron and steel industry has improved the efficiency with which it uses material and energy inputs substantially. In relative terms, fewer inputs are needed per unit of output now compared to 30 years ago. Between 1968 and 2001, the amount of crude steel produced from a tonne of material inputs increased by 6% to 830 kg, and energy efficiency almost doubled, with one terajoule (TJ) of energy producing 53 tonnes of steel in 2001 compared to 27 tonnes per TJ energy in 1968 (Figure 5.1). These improvements are related to the gradual closure of old plants and the uptake of continuous casting techniques.

Also in absolute terms, there are now fewer material and energy inputs required in total by the UK iron and steel industry compared to 30 years ago. This absolute decline in steel industry resource use is due to the contraction of the industry, the material output of which has declined by 29% in the time period studied, to 13.4 million tonnes (Mt) of steel products in 2001. Inputs for crude steel production have decreased by 50% in this time period, to just over 16 Mt in 2001. Energy consumption for the iron and steel industry has decreased by 63.5%, to 260,000 TJ energy consumed in 2001. From an environmental perspective, these are positive findings, as environmental impacts depend on absolute levels of resource use.

Economic labour productivity, measuring value added per worker, has fluctuated quite widely, with rapid productivity declines since 1995, although overall the trend seems to be moving upward. Value added per worker (in crude steel production) was just over £16,000 in 2001. However, material labour productivity shows constant improvements over the whole time period studied. Between 1979 and 2001, material output per worker increased by 75%, to 467 tonnes of crude steel output per worker in 2001. It is therefore clear that while steel production has declined in the UK, the associated employment has declined much more rapidly – by 84% between 1979 and 2001, to 29,000 employees in 2001.

In contrast to the resource efficiency indicators, resource productivity indicators – defined as value added per unit of resource use – show productivity declines over the period studied. The steel industry today generates less value per unit of material and energy input compared to 30 years ago. Between 1973 and 2001, the value added, in real terms, per tonne of material inputs in crude steel production decreased by 82% to £29, and the value added per TJ of energy consumed in the iron and steel industry decreased by 61% to £3,800 (Figure 5.2). The decline in value (due to a decline in steel prices, as discussed below) is also absolute, with the gross value added by crude steel production decreasing by 89%, to £554 million in 2001.

Figure 5.1
Energy efficiency in the
UK iron and steel industry

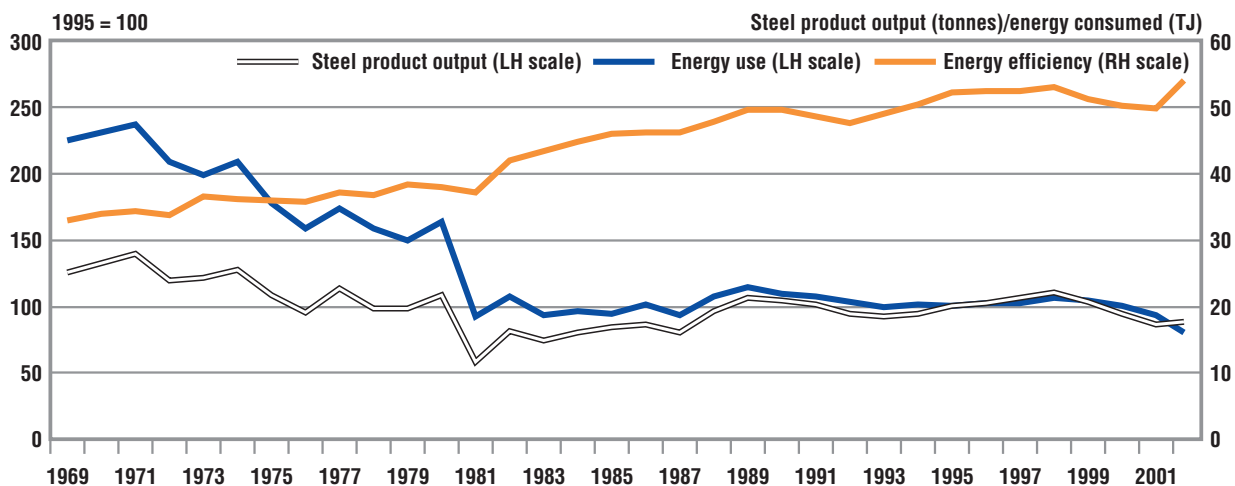

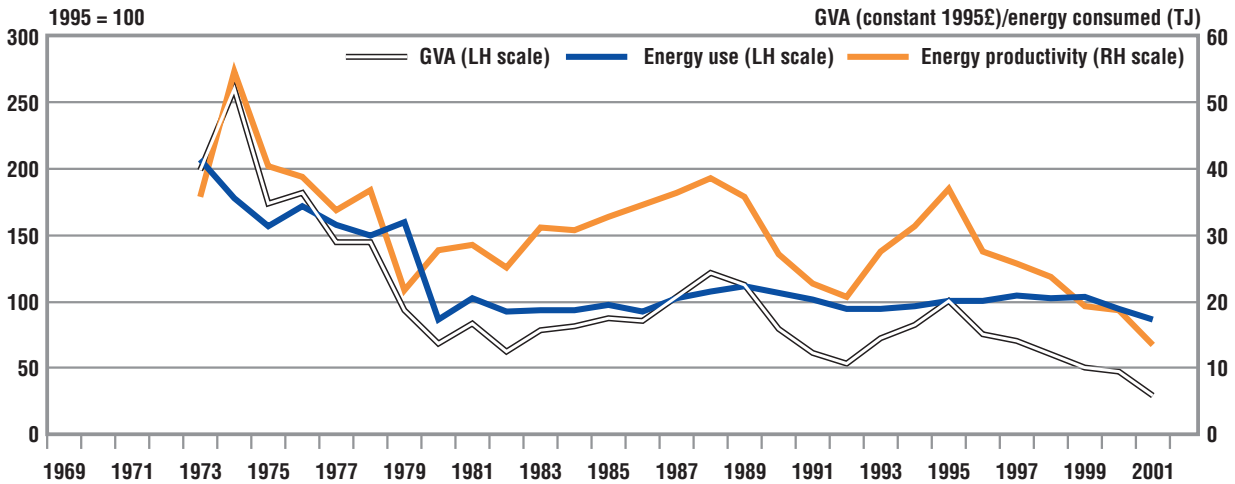

Figure 5.2 Energy productivity in the UK iron and steel industry

Aluminium

Due to a lack of adequate data, clear resource efficiency and productivity trends are hard to establish and results should be treated with some caution.

Both primary and secondary aluminium production have improved their energy efficiency, with primary aluminium production increasing its relative output from 16.6 to 18.2 tonnes per TJ energy consumed between 1980 and 2001, and secondary production from 115 to 128 tonnes per TJ between 1988 and 2001. For aluminium production as a whole (combining primary and secondary aluminium production), there have therefore been overall efficiency gains (Figure 5.3). Energy efficiency increased by 24% between 1988 and 2001, to produce 46 tonnes of aluminium per TJ energy consumed in 2001. However, the efficiency gains have been offset by the growth in total output, so that total energy use has increased. As aluminium output grew by 45% to almost 1.2 Mt, total energy consumption was up 15% to 25,000 TJ in 2001.

This analysis demonstrates the sensitivity of the industry, in terms of levels of energy efficiency and absolute energy use, to the relative proportions of primary and secondary aluminium production. According to the data analysed, primary smelting uses about seven times as much energy as refining and remelting activities. The significant improvements in energy efficiency are positive, as is the growth in the industry; however, the total increase in energy consumption is less desirable from an environmental point of view.

Economic labour productivity, value added per worker, has fluctuated quite widely, about what appears to be a gradual upward trend. Value added per worker was about £35,000 in 2001. However, material labour productivity shows constant and dramatic improvements over the whole time period studied. Between 1980 and 2001, material output per worker almost tripled, to 58 tonnes of aluminium products per worker in 2001. Even though UK production of aluminium semis and castings more than doubled between 1980 and 2001, the associated employment declined by 56% in the same time period, to 12,000 employees in 2001.

Figure 5.3 Aluminium energy efficiency

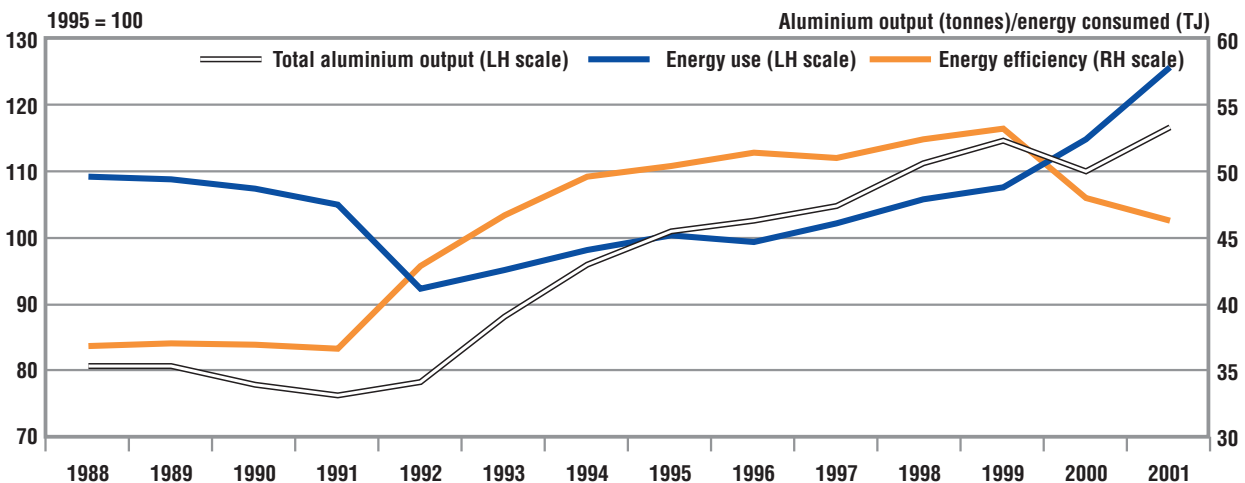

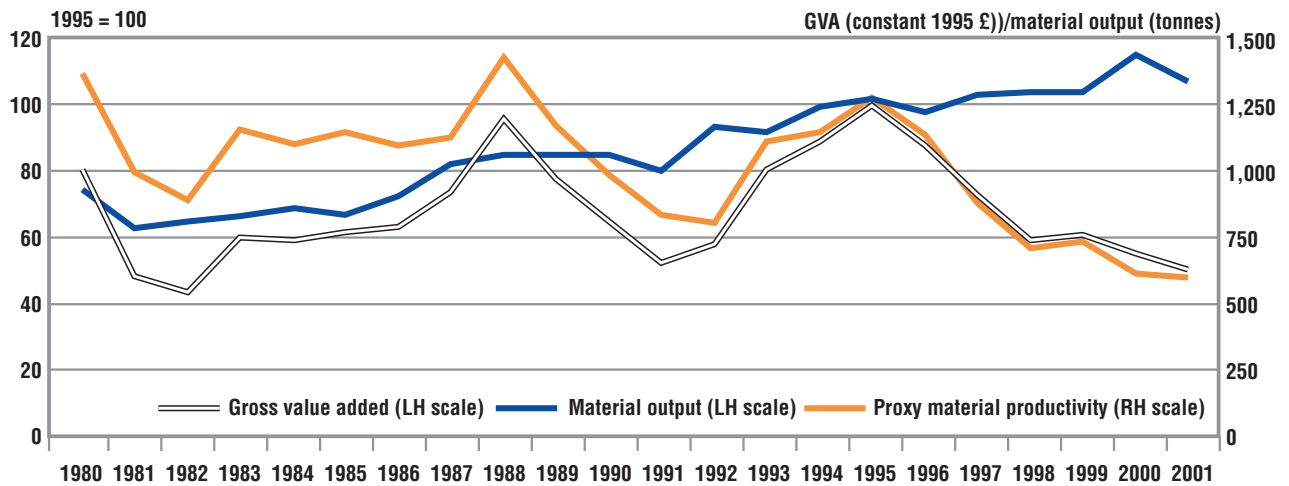

Figure 5.4
Aluminium proxy material productivity

In contrast to the energy efficiency indicator, the resource productivity indicator shows productivity declines over the period studied. It was not possible to create a material productivity indicator of the form value added per unit of material input for the aluminium industry, as no data on materials consumed were available. Data on outputs of semis and castings were therefore used to formulate a proxy material productivity indicator. This indicator showed wide fluctuations about what appeared to be a downward trend: the value added, in real terms, per tonne of aluminium output decreased by 56% to £600 in 2001. Despite growth in output, value added by the industry also declined in absolute terms (again due to a decline in prices): the value added by the UK aluminium industry decreased by 46%, to £416 million, between 1980 and 2001.

Value Chain Mapping

Iron and steel

Combining data on the values of different iron and steel material categories with data on their flows through the UK economy enabled a mapping of the UK iron and steel value chain to be drawn (Figure 5.5).

There is no longer any iron ore mined in the UK, and in 2001, the value of imports was just over £300 million in 2001. Like many other minerals, the price of iron ore has experienced a dramatic price decline in real terms.

Imports and exports of pig iron are very small in both material and value terms, with the value of imports totalling less than £30 million, and the value of exports less than £4 million. Exports of pig iron virtually disappeared after 1995; however, 2001 saw small exports but with a very high average monetary value per tonne compared to imported pig iron. The output of pig iron for the domestic market is valued at almost £600 million.

Imports and exports of crude steel totalled around £120 million and £220 million respectively. To estimate the values for crude steel output from the integrated route and the electric arc route, a more detailed level of breakdown on material flows than that used in the material flow analysis is necessary. The integrated route produces a negligible amount of alloy steels, so all output is assumed to be carbon steel. Using a value of £170/tonne for this material sub-category, the total output from this route is valued at £1.75 billion.

The EAFs, which use iron and steel scrap rather than iron ore as input, produce alloy steels in addition to basic carbon steels. The high value of these means that while the EAF output in material terms is considerably smaller than the output from the integrated route, the difference in value is not so large. The total value of output from the EAF route in 2001 was £1.11 billion. On a pound per tonne basis, the output from the EAFs therefore has an average value of £340/tonne.¹

¹ The very high value of the EAF output is due to the UK focus on the production in the EAFs of specialty steels rather than basic steels.

UK production of steel products is worth over £6.2 billion, and the values of imports and exports are also considerable: £2.9 and £2.6 billion respectively. International competition and cheap imports help explain the rising trend in imports since the early 1990s, as well as the decline in exports in the last few years.

² The waste disposal cost of £28/tonne used in the project was estimated by adding the 2001 landfill tax rate of £12/tonne to the average UK landfill gate fee of £16/tonne (Hogg and Hummel, 2002).

The large volume of end-of-life scrap arisings has a total value of about £500 million, and the smaller amount of prompt scrap arisings is valued at £125 million. Exports of scrap are growing rapidly, and represent a value of £385 million in 2001. Scrap imports are much smaller; however, due to the much higher average price paid for these materials, imports are actually worth more than the exports, at £479 million. Unfortunately, the trade statistics on scrap do not offer any detail on the types of scrap traded, but the imports are assumed to be specialty grades of high-value scraps.

Finally, while most of the iron and steel that arises as scrap is being recovered through recycling in the UK or, as is increasingly the case, exported for recycling elsewhere, a great amount is still being sent to landfill. 2 Mt of iron and steel contained in waste were sent to landfill in 2001 at an estimated disposal cost of £56 million.² Waste disposal costs are increasing, and the landfill tax is expected to eventually reach £35/tonne, at which level (assuming no change in gate fee) the amount of iron and steel disposed of would cost just over £102 million.

This lost material represents a potentially valuable source of raw materials for the iron and steel industry, and a potential income for those who could recover them. If the landfilled material could be recovered, and sold at the price of old steel scrap (£50/tonne), it would have a value of £100 million. The profitability of recovery depends on many factors: the rise in landfill tax; the landfill reduction targets to which local authorities are committed; and the steel packaging recovery targets set by the packaging regulations. These will increase the extent to which scrap collection, sorting and preparation are carried out.

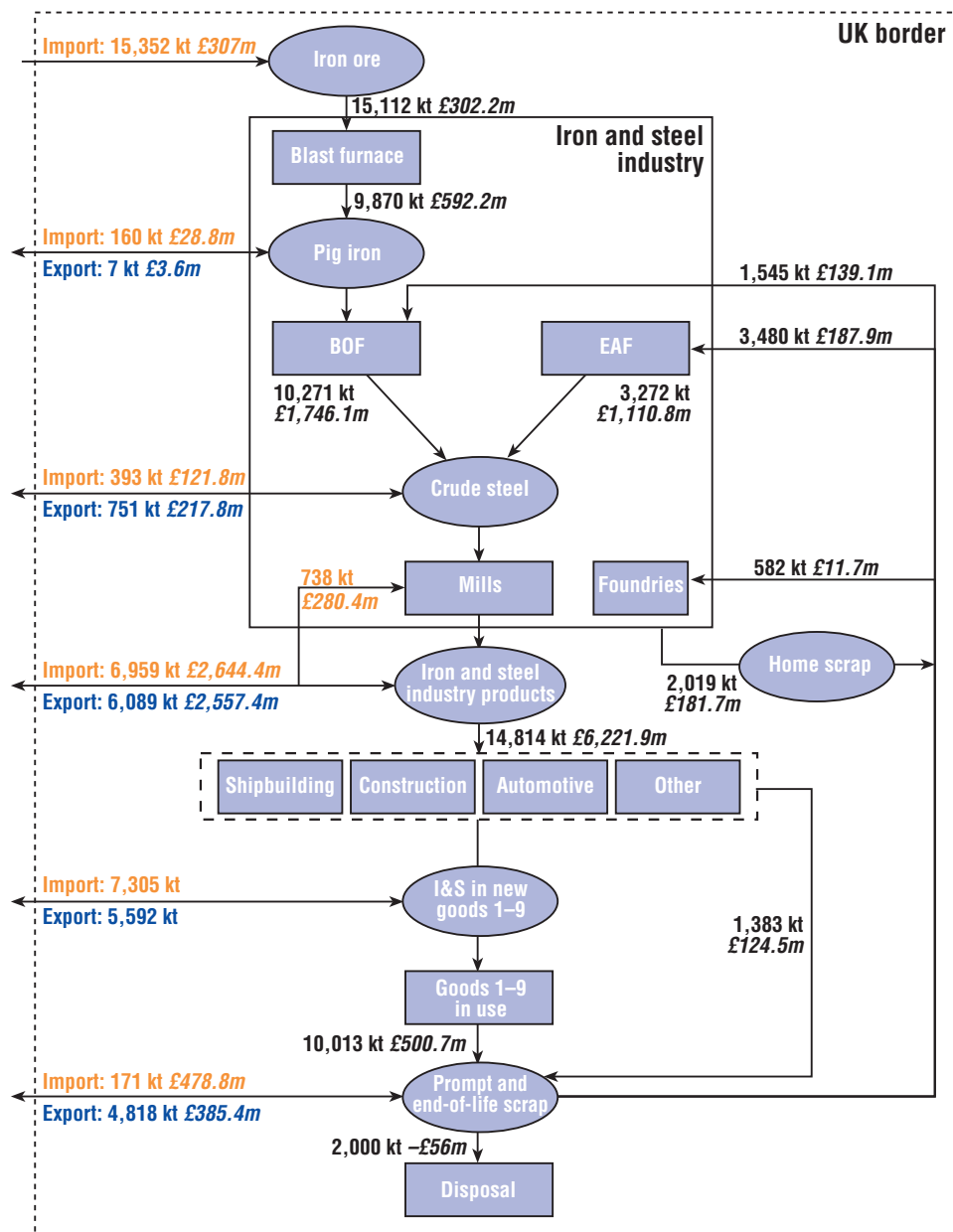

Figure 5.5 Current value chain for the UK iron and steel industry

Aluminium

Combining data on the values of different aluminium material categories with data on their flows through the UK economy enabled a mapping of the UK aluminium value chain to be drawn up (Figure 5.6).

As there is no longer any smelter-grade alumina production in the UK, there were no bauxite imports for aluminium production. The value of smelter-grade alumina imports was about £127 million in 2001.

Imports and exports of aluminium in 2001 totalled around £380 million and £290 million respectively. For domestic production, the value of the output of primary ingot is estimated at £344 million, refiners' ingot at £252 million, and remelters' ingot at £591 million – or a total of almost £1.2 billion. Remelter's ingot is usually not sold but internally transferred, although the value is displayed for purposes of illustration.

The value of the trade in semifabricated aluminium products is considerable, with imports worth £777 million and exports £385 million. The value of the domestic production of semis and castings is estimated at almost £1.9 billion. It is clear that the production of semis and castings is a very high value adding activity, the demand for which is increasingly met through imports. In 2001, imports met 46% of domestic demand (production + imports – exports) in material terms, but only 34% in value terms.

The large volume of end-of-life scrap, almost 700,000 tonnes, and the high value of aluminium scrap, means that there is significant value even at this stage of the chain –

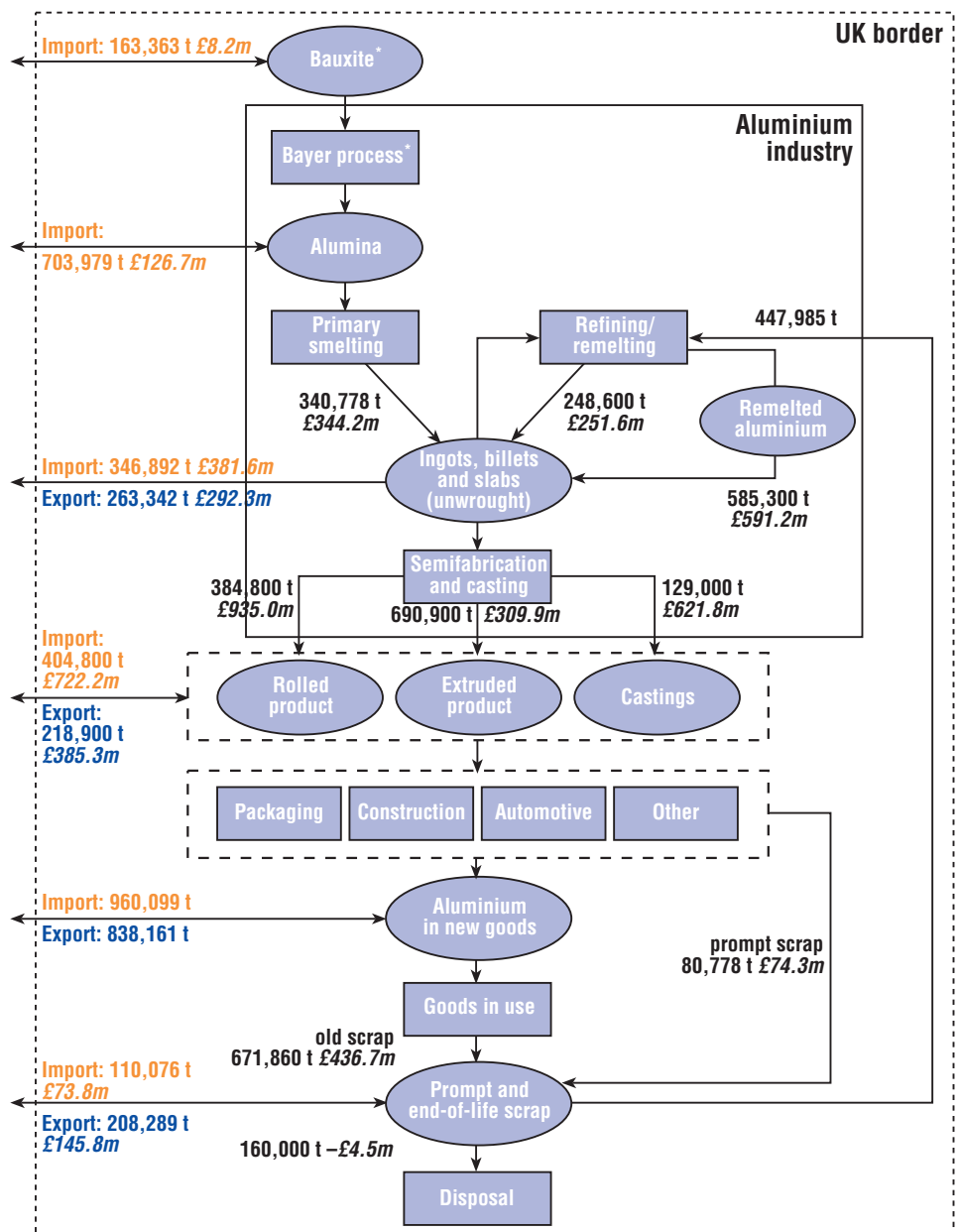

Figure 5.6 Current value chain for the UK aluminium industry

almost £440 million worth of old scrap arises from the consumption and use stage. Another £74 million worth of new scrap arises from the various aluminium consuming manufacturing sectors. Scrap imports in 2001 were worth around £74 million, and exports totalled around £146 million. Imports of aluminium scrap have increased substantially since the early 1990s.

Finally, while most of the aluminium that arises as scrap is being recovered through recycling in the UK or, as is increasingly the case, exported for recycling elsewhere, a substantial quantity is still being sent to landfill. About 160,000 tonnes of aluminium contained in waste was sent to landfill in 2001, at an estimated disposal cost of £4.5 million. Waste disposal costs are increasing, and the landfill tax is expected to eventually reach £35/tonne of landfilled waste, at which level (assuming no change in gate fee) the amount of aluminium disposed of would cost over £8 million.

The aluminium sent to landfill also represents a potentially very valuable source of raw materials for the aluminium industry, and a potential income for those who could recover them. If the landfilled material could be recovered, and sold at the price of old aluminium scrap (£650/tonne), it would have a value of £104 million.

Packaging Waste

The UK has implemented the EU Packaging Regulations through a system of tradable Packaging Recovery Notes (PRNs). The PRNs are bought by the companies that have recycling and recovery obligations from accredited reprocessors or accredited incinerators of packaging waste, and used as evidence that the companies have complied with their recycling/recovery obligations. Figure 5.7 gives a diagrammatic illustration of the system.

The flows of packaging materials are indicated by the unlabelled (black) arrows. These flows originate with the Obligated Producers and flow with packaged goods to businesses (and other organisations, which are here omitted for simplicity) and households, whence the packaging emerges as packaging waste. This is collected by Collectors. The fraction of materials that is recovered then flows to Reprocessors or Exporters. The former reprocess this into secondary packaging or other recycle materials, while the latter export it for recycling. The percentages shown for the Obligated Producers are the relevant percentage obligations for material or energy recovery.

The recovery is funded, in part, by the system of PRNs (PERNS from Exporters). These are bought by the Obligated Producers from the Reprocessors or Incinerators (not shown here for simplicity), who are the only bodies allowed to issue PRNs. The flows of money (red arrows) and PRNs (PERNs) (blue arrows) are shown in reverse directions.

Figure 5.7
Illustration of UK Packaging Waste Regulations Scheme

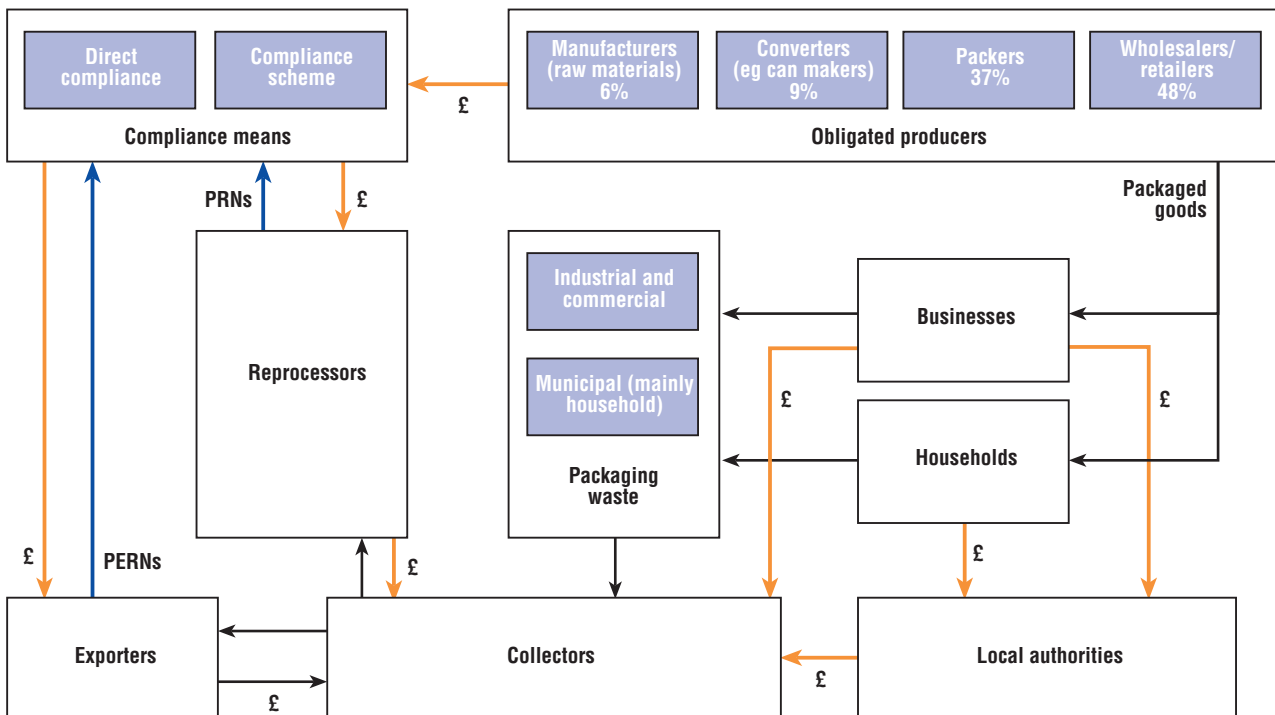

The Reprocessors use this money both to invest in more reprocessing capacity and (with Exporters) to pay Collectors to collect more packaging waste. Local Authorities (LAs) also pay Collectors to collect waste, including Packaging Waste, and may in turn be paid for any scrap metal collected. The money flows are shown net of any such payments. To the extent that PRNs increase the value of packaging waste, this will benefit LAs because the revenue generated from the sale of collected materials will to some extent offset what LAs will need to pay Collectors to carry out their municipal waste collection.

Conclusions and recommendations from the analysis of the operation of the PRN system are given in the next section.

6. Conclusions

The time series MFA methodology developed by the project was successfully employed to track flows and stocks of iron/steel and aluminium in the UK over the past 30–40 years. The findings of the MFA were also successfully combined with the VCA for an investigation of the associated values of the materials. MFA and VCA are similar methodologies in that both look beyond the unit of the individual firm to the whole economy, and both can handle complex systems. However, the different units of measurement employed by MFA and VCA – mass and value respectively – limits their individual usefulness as evaluation tools for decision making, as any effort at sustainable resource management will necessarily have to consider both these dimensions.

The limitations of the research are associated primarily with the complexity of the supply chains and the poor availability of certain types of data, particularly when tracking materials further downstream in the chain where they become embedded in goods and the metal contents for various categories of goods have to be assumed. Some of these limitations are compounded when data on material flows are combined with data on values. Data needs between the MFA and VCA tend to diverge at various stages.

However, in spite of these difficulties, the combination of material flows and value chains as demonstrated in this report is seen as a potentially very powerful way of analysing issues related to sustainable resource management.

Material Flow Analysis

Iron and Steel

A high level of closure was achieved in the iron and steel MFA: recovered and landfilled metals accounted for about 90% of EOL metal emerging from use. Modelling the service lives of products in use was necessary to achieve this closure. The historic data recorded no marked overall upward or downward trend in the ultimate demand for iron and steel contained in goods, in the past 25 years. The ultimate demand was about 11–13 million tonnes (Mt) per year. Of this demand, over 50% is currently met by imported goods. This implies that iron and steel in use in the UK are likely to come from abroad rather than from domestic iron and steel plants. The imports of iron and steel contained in goods grew to 7 Mt per year in 2001, about two Mt more than the exports.

Despite fairly stable ultimate demand for iron and steel, the quantities of iron and steel scrap available are still growing due to the long service lives of goods containing iron and steel. About 10 Mt of end-of-life (EOL) iron and steel scrap were released from use in 2001 in the UK, compared with 9.8 and 9.6 Mt in 1999 and 2000 respectively. Together with 1.3 Mt of prompt scrap arisings in 2001, this amounted to more than 11 Mt. Of this scrap, 4.8 Mt were exported and recycled abroad whereas 3.5 Mt were recovered and recycled domestically. A further 2 Mt ended up in landfill.

The recovery of iron and steel scrap arising in the UK thereby seems to be working relatively well in that about 70% of the scrap arisings is recovered and recycled. The detailed analysis suggested that a significant part of the potential scrap loss originates from products like domestic appliances, hand tools, metal furniture and other products that are included among the new goods categories of metal goods, and electrical and mechanical engineering. This highlights the need for further material flow analyses of these specific sectors.

The decline in scrap consumption is due to the decline in the number of operating EAFs, and therefore in UK scrap-reprocessing capacity. This has been associated with increasing exports of scrap over the years for recycling abroad. A reversal of the decline in EAF capacity would enhance the average environmental performance of UK iron and steel-making.

Looking at the upstream iron and steel flows, it can be concluded that domestically produced iron and steel products were not able to meet ultimate domestic demand, as

Box 6.1 Iron and Steel Material Flow Analysis Key Findings

- A high level of closure was achieved in the iron and steel MFA: recovered and landfilled metals account for 90% of all metal scrap emerging from use
- Ultimate demand for iron and steel has remained stable at around 11-13 million tonnes per year
- Over 50% of this demand is met by imports, however, around 40% of UK iron and steel production is destined for export
- Due to long life times of steel products, old scrap arisings are increasing despite stable demand - around 10 million tonnes of old steel scrap emerged from use in 2001
- Manufacturing generates 1.3 million tonnes of prompt scrap
- Of the old and prompt scrap that arose in 2001, 42% was exported and recycled abroad, 31% was domestically recovered and recycled, and 18% ended up in landfill

Box 6.2 Aluminium Material Flow Analysis Key Findings

- A very high level of closure was achieved in the aluminium MFA: recovered, landfilled, and dissipated metals account for 99% of all metal scrap emerging from use
- Ultimate demand for aluminium has risen dramatically, and is currently around 1 million tonnes
- 60-80% of this demand is met by imports, and around half of UK aluminium production is destined for export
- Due to the massive growth in the industry, old scrap arisings are increasing - around 622,000 tonnes of old aluminium scrap emerged from use in 2001
- Manufacturing generated 81,000 tonnes of prompt scrap in 2001
- Of the old and prompt scrap that arose in 2001, 28% was exported and recycled abroad, 48% was domestically recovered and recycled, and 23% ended up in landfill

there were massive imports and exports across the borders. This implies that although the amount of iron and steel produced was higher than the amount of iron and steel needed in the downstream sector, the specifications of the products are not in line with the downstream demand. It is conceivable from an economic perspective that, due to the global nature of the business, UK production could not economically produce all of the products that are required. In 2001, about 45% of domestically produced iron and steel products were different from those required by UK goods manufacturers and fabricators, and were destined to be consumed overseas. In addition, there is an increasing trend in imports of iron and steel products. The contribution of imports to the total consumption of iron and steel products increased from 20% in the 1970s to about 40–50% in the 2000s. This is partially due to the strength of the pound that makes it financially more attractive for UK goods manufacturers to import iron and steel products, and partially to the mismatch between domestic supply and demand in terms of product specifications.

Around 15 Mt of iron and steel products from both domestic and foreign producers were delivered to UK goods manufacturers and fabricators in 2001. In 2001, most of this iron and steel went into building and construction (26%), followed by other industries (20%), mechanical engineering (17%) and vehicles (17%). These four sectors currently consume 80% of the total deliveries of iron and steel products in the UK and have done so over the last 30 years. Similarly, the majority of iron and steel contained in goods going to use in the UK are in these sectors.

The demand pattern of crude steel and pig iron is in line with the declining demand for iron and steel products. Production of the three iron and steel material categories all experienced considerable reduction before 1980 and then gradually stabilised after 1980, but again showed a declining trend during the past 5 years.

Putting UK crude steel material flows into the global context shows that UK production and consumption contributed to one sixtieth and one tenth of world and EU production and consumption respectively, whilst the per capita consumption was about half of the EU level and one and a half times the world average.

Aluminium

A high level of closure was achieved in the aluminium MFA, again due to the modelling of the service lives of products in use. Recovered, landfilled and dissipated metals accounted for about 99% of EOL aluminium emerging from use. The historic data recorded a remarkable growth in the ultimate UK demand for aluminium contained in goods during 1958–2001. There was only a slight deceleration of this growth in 2001, possibly due to the business recession starting in that year. The ultimate demand in 2001 was about 1 million tonnes (Mt) per year. Of this demand, 60–80% was met by imported goods: i.e. aluminium in use in the UK comes primarily from abroad rather than from domestic aluminium plants. The imports of aluminium contained in goods grew to 850 thousand tonnes (kt) in 2001, about 350 kt greater than the exports.

In line with increasing ultimate demand for aluminium, the quantities of aluminium scrap available are constantly growing. About 622 kt of EOL aluminium scrap were released from use in 2001 in the UK, compared with 570 and 600 kt in 1999 and 2000. Together with 81 kt of prompt scrap arisings in 2001, this made up more than 700 kt. Of this scrap, around 200 kt were exported and recycled abroad, whereas around 340 kt were recovered and recycled domestically. A further 160 kt ended up in landfill. The recovery of aluminium scrap arisings in the UK thereby seems to be working relatively well in that about 70-80% of the scrap arisings is recovered and recycled. The detailed analysis suggested that a significant part of the potential scrap loss originates from products like EOL engineering goods, packaging and consumer durables.

As for recycling of aluminium scrap in the UK, there was growing output from remelters and refiners of semi-fabrications but a fairly stable output of unwrought products. Overall, the UK has seen a fast growing aluminium recycling industry. Despite the growth, there were still large volumes of scrap exports. The industry confirmed that there is enough capacity to deal with increasing scrap arising in the UK in the future as most of the secondary capacity is still not fully utilised (Alfed, 2003).

Looking at the upstream aluminium flows, domestically produced aluminium semi-fabrications and cast products have not been able to meet the ultimate demand as there have been massive imports and exports across the borders. Like iron and steel, this is

Box 6.3 Iron and Steel Resource Productivity and Efficiency Findings

Significant improvements in the efficiency with which resources – materials, energy, labour – are used in the UK iron and steel industry:

- Material efficiency has increased by 6%
- Energy efficiency has almost doubled
- Economic labour productivity, value added per worker, has fluctuated about an upward trend
- Material labour productivity, material output per worker, has increased by 75%

The efficiency gains and the contraction of the industry mean that the UK iron and steel industry in absolute terms now uses less material and energy resources than it did 30 years ago...

...but, these have been accompanied by a decline in the value added per unit of resource use:

- Value added per tonne of material inputs in crude steel production has decreased by 82%
- Value added per terajoule energy consumed has decreased by 61%

partially due to the globalisation of the business and economic reasons. About half of the domestically produced aluminium products are different from those required by UK goods manufacturers and fabricators and are destined to be consumed overseas. Around 900 kt of aluminium products were delivered to UK goods manufacturers and fabricators in 2001 from both domestic and foreign producers. Most of this aluminium went into building and construction (30%) followed by transport (21%), packaging (21%) and engineering (13%). These four sectors currently consume more than 80% of the total supply of aluminium products in the UK and have done so over the last 30 years. Similarly, the majority of aluminium contained in goods going to use in the UK is also contained in goods from these sectors.

There have been violently fluctuating demand patterns for aluminium ingot, billets and slabs. These fluctuations were mainly caused by imports and exports. This reflects how the UK market has been influenced by the global aluminium industry. Despite unstable supply of ingots, billets and slabs, there has been a consistently growing trend in production of semi-fabrications and castings in the UK. This is due to large manufacturing and industrial stocks of ingots, billets and slabs that buffer the volatile supply, and the absence of any close link between the supply of ingots/billets/slabs and production of semi-fabrications and castings.

Value Chain Analysis

Resource Productivity and Efficiency in the Steel and Aluminium Industries

There have been some improvements in steel industry material efficiency, and quite substantial improvements in the energy efficiency associated both with steel and aluminium production in the UK. Energy efficiency in steel production has almost doubled, and these efficiency gains in combination with a decline in production mean that absolute energy consumption for UK steel production is significantly less than it was 30 years ago. Energy efficiency in aluminium production has also increased substantially; however, output has also increased and therefore total energy requirements are larger now than 15 years ago. Also, the analysis revealed the sensitivity of energy efficiency and total energy consumption to the relative proportions between primary and secondary aluminium production in the UK, as the latter uses one seventh less energy according to the energy data analysed. Currently, both primary and secondary aluminium production is growing rapidly in the UK, although secondary production seems to be increasing at a faster rate.

Economic labour productivity, measured by value added per worker, shows significant fluctuations over the time period studied. However, there seems to have been a gradually increasing trend over the time considered. Material labour productivity (material output per worker), on the other hand, has increased dramatically for both iron and steel production.

In contrast with the indicators of material and energy efficiency, which all show improvements, measures of material productivity (value added per unit of material input) and energy productivity (value added per unit of energy input) for both iron and steel production demonstrate declining trends; that is, the industries are now generating less value added per unit of primary resource use.

It is interesting that, for both steel and aluminium, resource efficiency indicators demonstrate significant improvements over the time period studied, whereas resource productivity indicators, employing monetary output variables, demonstrate declines. This reflects the fact that prices of metals have fallen substantially in real terms over the last few decades. The price, in real terms, of steel fell by a factor of 4, and the price of aluminium almost halved, between 1974 and 2001.

The findings in this section raise important questions for the use of resource productivity indicators, involving monetary output measures, for examining trends relating to environmental impacts and resource use at the sectoral level. The products of sectors like steel and aluminium are globally traded commodities, subject to intense competitive pressures and, therefore, pressures to cut costs. Wages are a major element of costs and therefore there is a relentless drive to increase labour productivity, either by increasing output per worker, or by reducing employment while keeping output constant. The analysis showed that labour productivity in both steel and aluminium has increased substantially.

However, wages are a major element of value added as well as a major cost. If a sector's wage costs fall, permitting a fall in price, so will its value added, and this has happened with both steel and aluminium, as seen above. With sectoral resource productivity measured as sectoral value added per tonne of resources (either as input or output), sectoral resource productivity will decline. However, this says nothing about the efficiency with which the resources have been used.

For the economy as a whole, a resource productivity measure of Gross (National) Value Added per unit of material or energy use would still be a meaningful indicator, because the employment base remains the same. Sectors that shed labour will be balanced by sectors that absorb it, so that the labour input of the economy as a whole will be unchanged by these shifts. Therefore, changes in total value added will provide an indication of the productivity of the labour force, and value added per unit of resource use will give a meaningful indication of the relative resource use to create that value added.

Value Chain Mapping

Iron and steel

Table 6.1 summarises the value chain mapping of the UK iron and steel industry. From the Table, it is clear that the major value adding activities are crude steel production, particularly through the electric arc furnace (EAF) route, and the production of steel products. However, there are very large quantities of EOL steel scrap (see above), the value of which is estimated at £500 million. The cost of the steel revealed by the MFA to be landfilled as waste is estimated at £56 million. On the other hand, if this material could be recovered and sold at the price of old scrap (£50/tonne), it would have a value of £100 million.

Material category	Domestic production		Imports		Exports		Net imports = Imports – Exports	
	Weight (kt)	Value (million)	Weight (kt)	Value (million)	Weight (kt)	Value (million)	Weight (kt)	Value (million)
Iron ore			15,112	£302.20			15,112	£302.20
Pig iron	9,870	£592.20	180	£28.80	7	£3.80	153	£25.20
Crude steel	BOF 10,271 EAF 3,272	£1,1746.10 £1,110.80	393	£121.80	751	£217.80	-358	-£96.00
Steel products	14,814	£6,221.90	7,697	£2,924.80	6,089	£2,557.40	1,608	£367.40
Scrap	new 1,383 old 10,013	£124.50 £500.70	171	£478.80	4,818	£385.40	-4,647	£93.40
Scrap to landfill	2,000	-£56.00						

Table 6.1
Iron and steel summary table³

The final column displays net imports (imports – exports) in both weight and value terms for the different iron and steel material categories. In weight terms, there was a trade surplus (exports exceed imports) for crude steel and scrap. However, in value terms, there was a trade surplus only for crude steel, due to the very high value of scrap imports. Net imports of steel in steel products are about 11% of domestic steel production incorporated into products.

Aluminium

The major value adding activities are aluminium production and the production of semifabricated aluminium products and castings. However, aluminium scrap is also a highly valuable material, and the total value of old and new scrap is estimated at over £500 million. In spite of this, the MFA showed that substantial quantities of aluminium are disposed of as waste, at an estimated cost of £4.5 million. On the other hand, if this

³ CO₂ emissions were not added to this table, as data on greenhouse gas emissions from all the various processes were unavailable and/or insufficiently transparent.

material could be recovered and sold at the price of old scrap (£650/tonne), it would be worth £104 million.

Table 6.2 includes, in addition to weight and value data, estimates of CO₂ emissions associated with the various material categories. These estimates should be treated with caution, but can nonetheless give an idea of the order of magnitude of greenhouse gas emissions associated with the different stages in the aluminium production and use chain. It can be seen that the great majority of CO₂ emissions – over 3.3 million tonnes – arise from the primary production of aluminium, while CO₂ emissions from secondary production amount to 384 kt. The emissions data for these processes include the indirect greenhouse gas emissions associated with electricity generation and transmission. CO₂ emissions from the production of semi-fabricated products amount to 526 kt, although these are direct emissions only.

The final column displays net imports (imports – exports) for the different aluminium material categories. In terms of weight, value and greenhouse gas emissions, there was a trade surplus (exports exceed imports) only for aluminium scrap. Greenhouse gas emissions associated with UK aluminium production and use are largely associated with domestic production. The assumed quantity of CO₂ emissions from net imports are around one third (1,342 kt) of those from domestic manufacture (4,378 kt).

Material category	Domestic production			Imports			Exports			Net imports = Imports – Exports			
	Weight (kt)	Value (million)	CO ₂ (kt)	Weight (kt)	Value (million)	CO ₂ (kt)	Weight (kt)	Value (million)	CO ₂ (kt)	Weight (kt)	Value (million)	CO ₂ (kt)	
Bauxite*				163	8.2								
Alumina				701	126.7	943				704	127.0	913	
Aluminium	primary refiners' ingot	341	£344.20	3385									
	remelters' ingot	249	£251.6	199	347	381.6	1113	263	292.3	845	84	89	268
		585	£591.20	185									
Semi-fabricated products	rolled products	385	£935.0	296									
	extruded products	177	£309.9	160	405	777.2	309	219	385.3	167	186	392	142
	castings	129	£621.8	68									
Scrap	new	81	£74.3	83	110	73.8	12	208	145.8	23	-88	-72	-11
	old	672	£436.7										
Scrap to landfill	160	-£4.5	na										

Note: Data on CO₂ equivalent emissions for alumina from SimaPro, for scrap (referring to the transport emissions generated in their collection) from Davis (2004), all other EAA (2000). For imports of aluminium and semi-fabricated products, the same proportions that exist in the UK in terms of production of sub-categories have been assumed

* Bauxite imports are not for aluminium production, displayed only for illustration purposes.

Table 6.2
Aluminium summary table

Packaging Waste

It seems likely that the UK system of implementing the Packaging Regulations through the system of tradable Packaging Recovery Notes (PRNs) has generally contributed to a cost-effective increase in the recycling of packaging waste. However, one reason why the costs of UK compliance with the Packaging Directive have seemed low is that local authority collection of packaging in the household waste stream is largely paid for by taxes. Another reason why these costs appear low is that, compared to some other European countries and despite the fact there has been an increase in collection of around 11% of all packaging waste, and an increase in reprocessing of around 8%, the overall recovery rate is still modest.

The lack of a viable mechanism for sanctioning failing compliance schemes has led to lower levels of demand for PRNs, reducing the marginal costs of packaging recycling and recovery in the UK, and hence, the prices paid for PRNs. The fluctuations in the PRN price have not helped planning for the development of either the collection or reprocessing infrastructure. PRN prices seem strongly driven by recycling targets. It seems

Box 6.4 Aluminium Resource Productivity and Efficiency Findings

Significant improvements in the efficiency with which resources – energy, labour – are used in the UK aluminium industry:

- Energy efficiency for the industry as a whole has increased by 24%
- Economic labour productivity, value added per worker, has fluctuated about an upward trend
- Material labour productivity, material output per worker, has almost tripled

However, the efficiency gains have been offset by the overall growth in the UK aluminium industry, particularly the increase in the proportion of the more energy-intensive primary aluminium production. Therefore, the industry in absolute terms now uses more energy than it did 15 years ago.

The efficiency improvements have been accompanied by a decline in the value added per unit of resource use:

- Value added per tonne of material outputs in aluminium production has decreased by 56%

that unless targets continually increase, PRN prices fall back, which hinders the smooth development of the collection and reprocessing infrastructure.

A positive conclusion from the price sensitivity of PRNs to targets is that, in the industrial and commercial sector at least, it seems that once collection and reprocessing infrastructure is in place, reduced levels of subsidy are required to keep it operational. It is not yet known whether this would also apply to the household sector, but it seems likely to be the case.

The volume of steel and aluminium packaging in household waste, the increasing targets for recovering packaging waste in the future, and pressures to recover other waste streams from households, make it both desirable and necessary for household waste to play a larger part in meeting the packaging waste recovery targets in the future than it has in the past. This means that local authorities are going to need greater levels of recycling finance. To be consistent with the producer responsibility principle, this finance should be provided by the packaging industry rather than by the taxpayer.

These conclusions suggest a number of recommendations in respect of steel and aluminium to ensure that the recycling target for 2008 is met. In order to facilitate the steady and predictable development of recycling infrastructure, recycling targets should be set to increase on an annual basis. It would seem prudent to set the targets slightly higher than the statutory minima, to allow some room for the kind of miscalculations and data problems that have occurred in the past.

To ensure that PRNs maintain the price necessary to develop new recycling activities, there should be sanctions for compliance schemes (passed on to their member obligated producers) that fail to meet their obligation to purchase PRNs. Defra has recently announced that scheme operators will be legally responsible for discharging their recycling obligations, and will be liable for penalties if they fail to do so.

To apply the concept of producer responsibility to the household waste stream, the packaging industry should provide increased funds to local authorities (LAs). To give an incentive to LAs to collect packaging waste from households, they could be paid a premium price for such waste by reprocessors, funded out of PRN revenues. This would in turn require a higher PRN price, which would incentivise packaging producers to be more efficient in their use of packaging.

It seems likely that the most efficient resource recovery infrastructure, and the one best suited to give effect to the proximity principle (that waste should be managed as locally as possible), would be integrated local facilities which handled both commercial and industrial waste along with municipal waste. This would enable economies of scale in waste handling to be achieved from the waste from a relatively small area. The Government should provide incentives, perhaps out of landfill tax revenues, for the creation of these integrated local waste management facilities, from which the recovery of all materials ending up as packaging waste could be maximised irrespective of their source.

7. References

- Birat, J.P., Russo, P., Gros, B., de Guerry, G. and Dalsheimer, J. (1999), Usinor fosters recycling and its long term sustainability. *Proceedings from the 4th ASM international conference and exhibition on the recycling of metals*, 17th – 18th June 1999, Vienna, Austria.
- Danckwerts, P.V. (1953), Continuous flow systems – distribution of residence times. *Chem.Eng.Sci.* 2: 1-12.
- DETR (1999), *A better quality of life: A strategy for sustainable development for the UK*. London: The Stationery Office.
- DETR (2000), *Waste Strategy 2000: England and Wales*. London: The Stationery Office.
- EAA (2002), *Market Report 2002*. www.aluminium.org
- European Commission (2001), *Environment 2010: Our future, Our choice. The Sixth Environmental Action Programme*. COM (2001) 31 final , Brussels, 24.1.2001.
- Graedel T. E., Bertram M., Fuse K., Gordon R. B., Lifset R., Rechberger H. and Spatari S. (2002). The contemporary European copper cycle: The characterization of technological copper cycles. *Ecological Economics*, 42 (1-2): 9-26.
- Hogg, D. and Hummel, J. (2002), *The Legislative Driven Economic Framework Promoting MSW recycling in the UK*. Final report to the National Resources and Waste Forum. Bristol: Eunomia Research and Consulting.
- House of Commons (2003), *UK Steel 2003*. Ninth Report of Session 2002-03. House of Commons Trade and Industry Committee. London: The Stationery Office.
- IISI (2002), *Steel statistics yearbook 2002*. IISI.
- Linstead, C. and Ekins, P. (2001), *Mass balance UK. Mapping UK resource and material flows*. Royal Society for Nature Conservation.
- Michaelis, P. and Jackson, T. (2000a), Material and energy flow through the UK iron and steel sector. Part 1: 1954 -1994. *Resources, Conservation and Recycling*, 29: 131– 156.
- Michaelis, P. and Jackson, T. (2000b), Material and energy flow through the UK iron and steel sector. Part 2: 1994 – 2019. *Resources, Conservation and Recycling*, 29: 209 – 230.
- PIU (2001), *Resource productivity: making more with less*. London: The Cabinet Office.
- Porter, M. E. (1985), *Competitive Advantage: Creating and Sustaining Superior Performance*. New York: The Free Press.
- Strategy Unit (2002): *Waste not, want not. A strategy for tackling the waste problem*. November 2002.

Appendix: Mass Balance Reports

Geographical	Sector	Material
Completed		
<ul style="list-style-type: none"> ■ Isle of Wight (e) (w) (bw) ■ City Limits Report (London) (e) (w) (bw) ■ UK book (e) ■ UK book 2 (e) (w) ■ South East Report (e) (w) www.takingstock.org ■ Northern Ireland Report (w) http://www.northern-limits.com/ ■ Scotland Report (w) http://www.scotlands-footprint.com/ 	<ul style="list-style-type: none"> ■ Agricultural Report (Marcus Hodge)(e) (bw) ■ Agricultural Waste Report (C-Tech) (e) (w) ■ Construction Report (Viridis)(e) (w) (bw) ■ BedZed Construction Report pt1 (e) (w) (bw) ■ 4sight – Rocks to Rubble – eco-region (e) (w) (bw) ■ Public sector Report (Waste Watch) (e) ■ Solvent Waste in UK Furniture Manufacturing Industry ■ Exhibition Industry ■ <i>Waste Management for Schools</i> ■ <i>Publishing</i> ■ Electricity Report (e) ■ Foundry Report (e) (w) (bw) ■ UK Status Report on Waste from Electrical & Electronic Equipment (ICER) 	<ul style="list-style-type: none"> ■ <i>Carbon UK Report</i> ■ UK Tyres Report (Viridis) (e) (w) (bw) ■ European Tyres Report (Viridis) (e) ■ Chemical Report ■ Thermal Methods Report (e) (w) (bw) ■ PIRA Packaging Report (e) (w) (bw) ■ Benchmarking Wood Combustion ■ <i>Large Scale Glass Manufacture</i> ■ <i>Sustainable Timber Waste</i> ■ <i>Furniture Packaging Optimisation</i> ■ Plastic Report (e) (w) ■ <i>Sustainable Markets for Waste Glass from Fluorescent Tubes and Lamps</i> ■ Composting of Wood Waste from Furniture Industry (e) ■ <i>Paper</i> ■ <i>Material flows of iron, steel and aluminium</i> ■ Civil Engineering Application of Tyres (Viridis) (e) (w) http://www.trl.co.uk/viridis/1024/mainpage.asp?page=113
To be completed		
<ul style="list-style-type: none"> ■ Ecological Budget UK (WWF), regional series 	<ul style="list-style-type: none"> ■ Mass Balance Study into Waste Arisings from the Food & Drink Processing Industries ■ National Health Service (w) http://www.materialhealth.com/ ■ Financial Sector ■ Motor Industry ■ Newspaper ■ Poultry ■ Ceramics ■ Magazines ■ Pigs ■ Food chain 	<ul style="list-style-type: none"> ■ Embodied Wood: The UK Mass Balance and Efficiency of Use ■ Mass Balance & Scenario Analysis for UK Clothing & Textiles ■ <i>Nitrogen</i> ■ Glass

Key:
(e) = available electronically; (w) = website link available (www.massbalance.org); (bw) = available from Biffa website (www.biffa.co.uk/massbalance/)

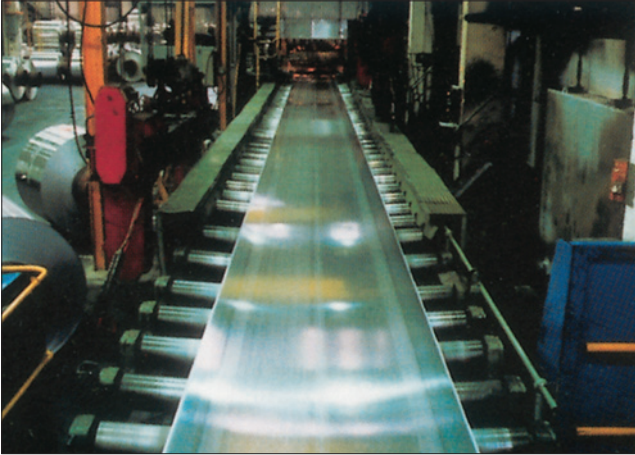

Aluminium rolling mill © Alfred



Steel can recycling © Corus

ALFED



Aluminium for Future Generations 

Billboard
Programme on
Sustainable
Resource
Use